

TRIPLE BOOSTER SETS

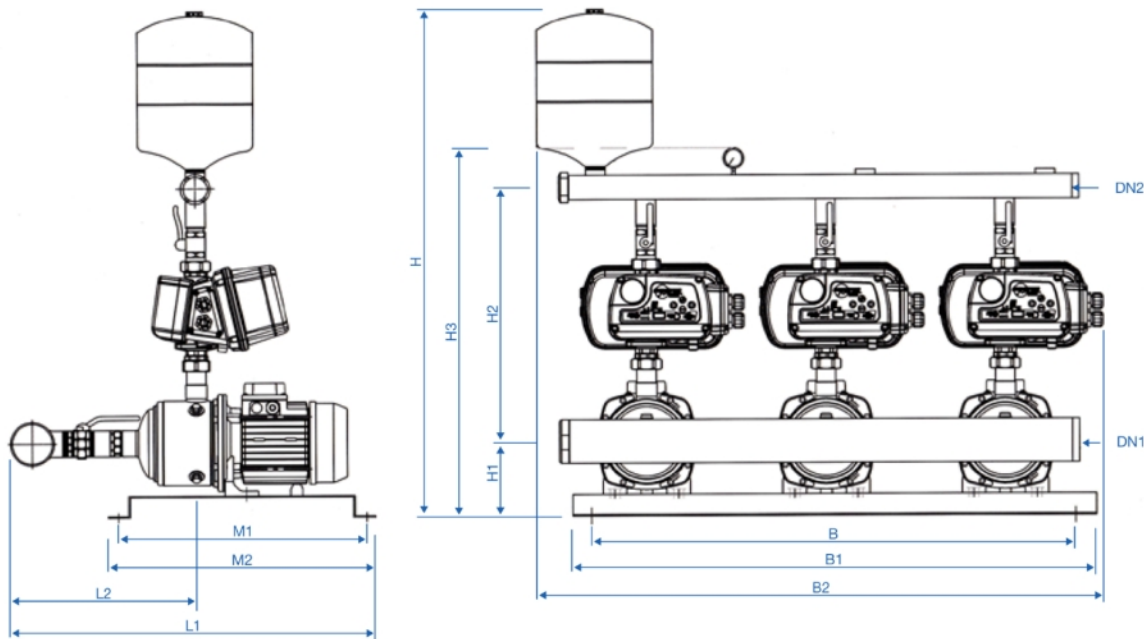

Model	DN1	DN2	B	B1	B2	H	H1	H2	H3	L1	L2	M1	M2	Weight (KG)
3MX306MT/8DPT	2 1/2"	2"	850	900	995	1070	125	445	475	676	391	300	330	73.0
3MX308MT/8DPT	2 1/2"	2"	850	900	995	1070	125	445	475	724	439	300	330	82.0
3MX506MT/8DPT	2 1/2"	2"	850	900	995	1070	125	445	475	676	391	300	330	78.0
3MX508MT/8DPT	2 1/2"	2"	850	900	995	1070	125	445	475	724	439	300	330	87.0
3MX1004MT/8DPT	3"	2 1/2"	850	900	995	1115	125	483	720	735	440	300	330	93.0
3MX1006MT/8DPT	3"	2 1/2"	850	900	995	1115	125	483	720	810	500	300	330	114.0

TRIPLE SETS	Model	Supply Voltage	Motor P2 (kw)	Inlet	Outlet	Max Flow (l/Min)	Max Head (metres)	Full Load Current (Amps)
	3MX306MT/8DPT	230v-1ph-50hz	3 x 0.65	2 1/2"	2"	240	45	15.0
	3MX308MT/8DPT	230v-1ph-50hz	3 x 0.90	2 1/2"	2"	240	68	21.0
	3MX506MT/8DPT	230v-1ph-50hz	3 x 0.90	2 1/2"	2"	360	46	21.0
	3MX508MT/8DPT	230v-1ph-50hz	3 x 1.30	2 1/2"	2"	360	68	24.0
	3MX1004MT/8DPT	230v-1ph-50hz	3 x 1.50	3"	2 1/2"	600	48	27.0
	3MX1006MT/8DPT	230v-1ph-50hz	3 x 2.20	3"	2 1/2"	600	72	33.0

Tanks Direct Ltd, Channel House, Mart Road, Minehead, Somerset, TA24 5BJ

01643 703358 | sales@tanks-direct.co.uk | www.tanks-direct.co.uk



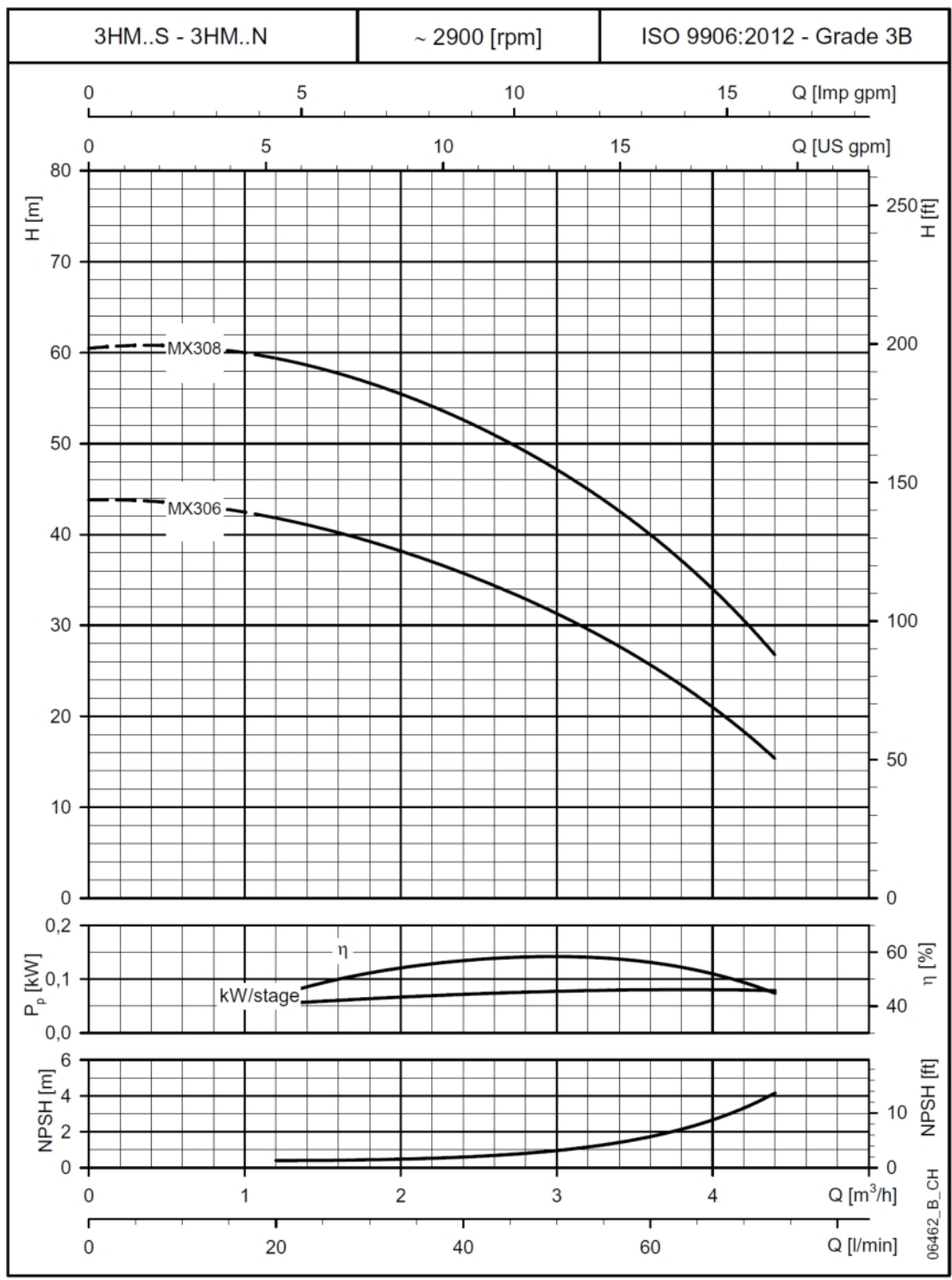

Tanks Direct Ltd, Channel House, Mart Road, Minehead, Somerset, TA24 5BJ

01643 703358 | sales@tanks-direct.co.uk | www.tanks-direct.co.uk



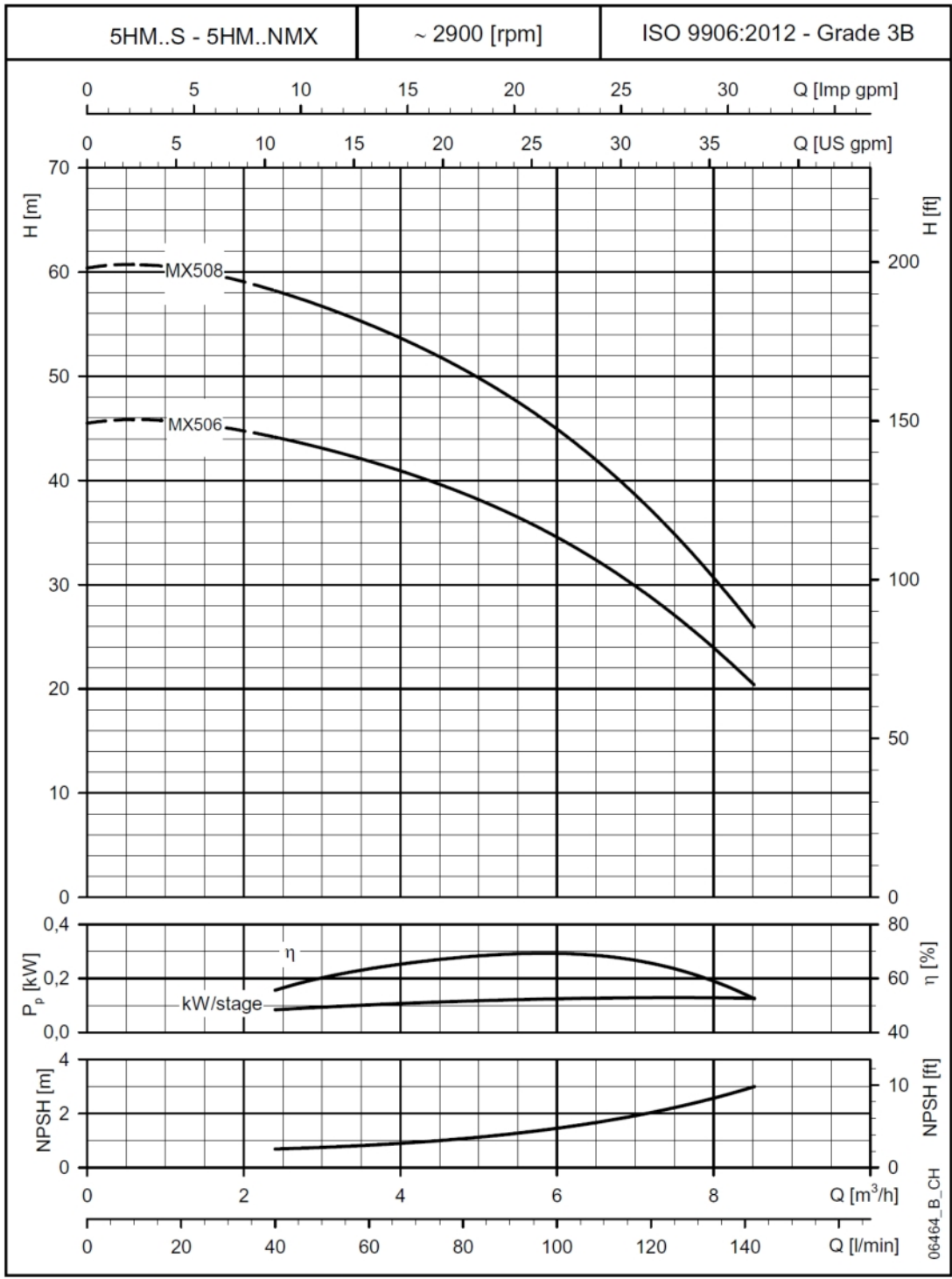

Tanks Direct Ltd, Channel House, Mart Road, Minehead, Somerset, TA24 5BJ

01643 703358 | sales@tanks-direct.co.uk | www.tanks-direct.co.uk



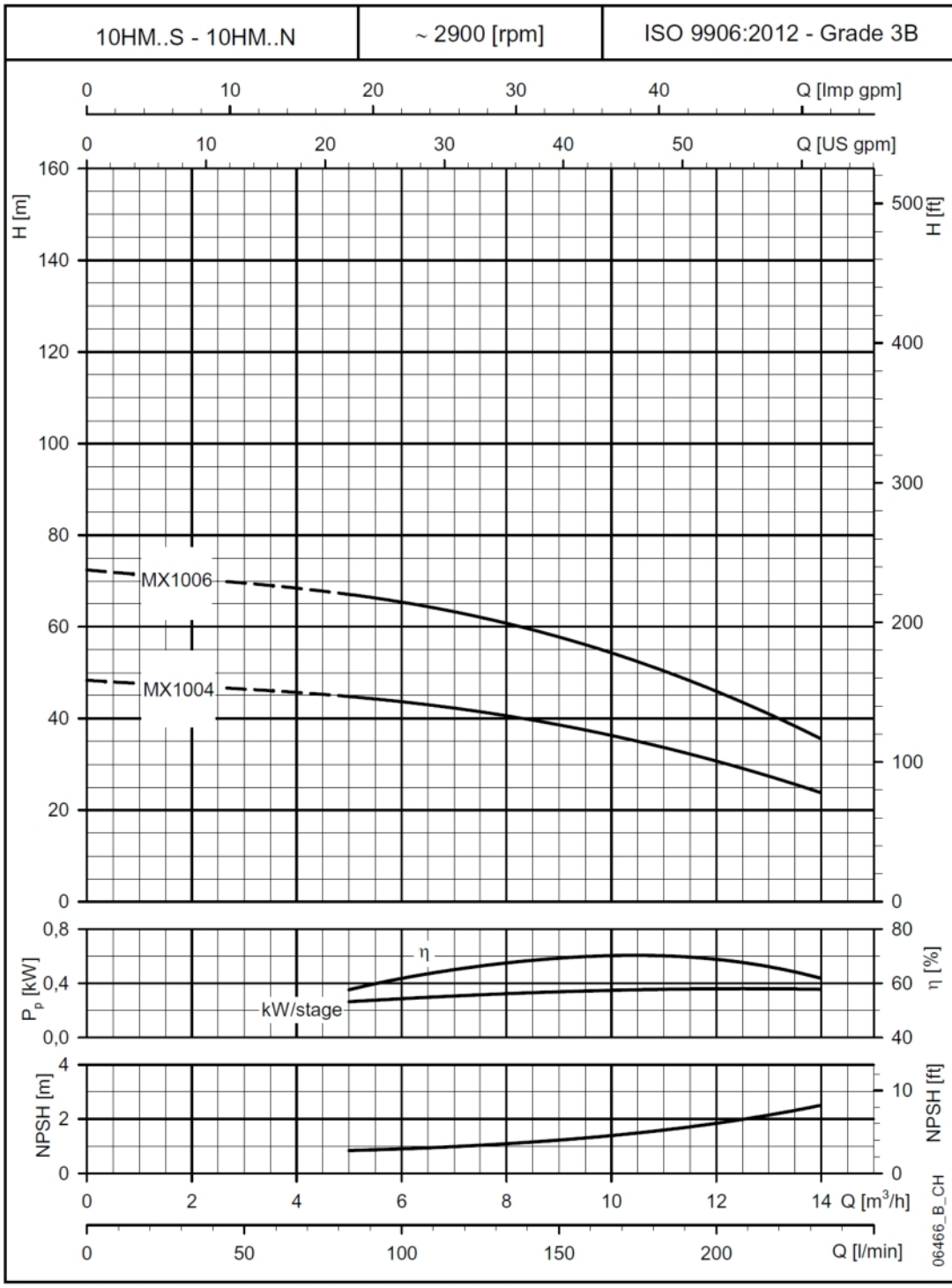

These performances are valid for liquids with density $\rho = 1.0 \text{ Kg/dm}^3$ and kinematic viscosity $\nu = 1 \text{ mm}^2/\text{sec}$.

Tanks Direct Ltd, Channel House, Mart Road, Minehead, Somerset, TA24 5BJ

01643 703358 | sales@tanks-direct.co.uk | www.tanks-direct.co.uk

