

STORAGE TANK

INSTALLATION GUIDE



CONTENTS

SECTION A: Product Introduction & Pre Start Information	Page
1. Tank structure build strengths	3
2. Tank base requirements	3
3. Tank erection safety advice	3
4. White Rust Prevention	3
5. Risks to consider	4
6. Suggested safety equipment	4
7. Options for cushioning liner	5
8. Tank base specification	6-7
SECTION B: Tank Kit Contents & Tooling Requirements	
1. Tank kit contents	8
2. Optional items	8
3. Tooling requirements	8
SECTION C: Installation Instructions (Written)	
1. Marking out the base	9
2. Unbanding the panels	9
3. Fixings	10
4. Erecting the steel walls	10
5. Erecting the upper ring	11
6. Final checking and fixing	11
7. Fit the capping	12
8. Preparation for fitting side wall assembly	12
9. Installation and fitting of the Liner Cushioning	13
10. Unfolding and fitting the liner	13-15
SECTION D: Optional Items (with installation advice)	
1. Galvanised outlets	16
2. Tank side outlet assembly (Flanged), checking and filling and checking and filling	17-19
3. Tank base outlet arrangement – Pipe	20
4. EPDM liner repair kit	21
5. FPP liner repair kit	22
6. Fleece Example	23
SECTION F: Tank maintenance and winterisation.	24-25

SECTION A.

PRODUCT INTRODUCTION and PRE-START INFORMATION.

1. The Tank Structure Build Strengths

Comprehensive stress calculations for our entire range of tanks have been carried out by chartered external consultants to provide builds which comply with both British BS 5950 and European BSEN 1993 structural, wind and (where a steel cover is fitted,) snow loading requirements.

The specified panel thicknesses, the bolt sizes, the use of double washers, the fitting of base anchor brackets and the liner support and protection within the tank are all integral to the safety calculations for our tanks.

2. The Tank Base Requirements

Tank base supplied by others (See Page 6)

In order to comply with U.K and E.C agricultural directives, it is necessary to erect the tank on a level concrete base with a minimum thickness of 100mm depending on local soil conditions. It may also be necessary to add reinforcement into the concrete.

The base slab (round / square / hexagonal, etc), should measure 600mm in excess of the diameter of the tank to ensure there is a minimum of 300mm of base beyond the outer tank wall. The base should be level over its entire surface and should be free from any sharp projections.

There should also be a further one metre minimum of clear ground, to allow unrestricted access for installing the tank. If platforms or mechanical lifting devices are used, a larger, clear, firm ground area may be required.

The base should be constructed of pre-mix concrete to a strength of not less than 35 N/mm. sq (C35 Mix). Once poured and levelled, the base should be left to cure for a minimum of 96 hours prior to installation of the tank.

3. Tank Erection Guidance and Safety Advice

(provided for guidance only)

Safety Information.

Our tanks have been designed to be installed using basic industry standard methods this will involve the “safe” use of ladders and step ladders. Installers should therefore take note and abide wherever possible, to the recommended installation methods. They should also familiarise themselves with the latest local and national ‘health and safety’ published advice regarding the safe use of the equipment and tooling they are using.

4. White Rust

If your tank is not being erected immediately please remove the outer polythene packaging and store in a dry environment. Ensure the tank is kept on the pallet to keep it from direct contact with the ground. Where possible do not leave an uncovered tank lying in the open, but store undercover and away from open doorways. This will reduce the risk of white rust forming on the panels of the tank.

Risks to Consider

Provide Sufficient Labour

Most tanks can be erected in the standard build method by two experienced operatives, however when erecting the taller tanks additional trained labour would be recommended.

Windy Conditions

It is advised that tank erection should not be attempted in excessively windy conditions, as handling the tank panels or attempting to install the liner could result in personal injury or damage to components or property.

Lacerations

Be aware that tank panels and galvanised cover panels may have sharp edges. Protective gloves should be used at all times.

Wet Conditions

Although tank erection can be done in wet conditions, be fully aware that steel panels become slippery when wet and that it would be extremely dangerous to be working on panel surfaces when wet.

Lifting Heavy Panels

Most panels can be lifted and handled safely by one person. However the thickest panels (1.6mm @ approx 34kg) should be a two man lift, especially if lifting above the waist.

Use of Podgers

Take care when pushing podgers through the wall of the tank, there may be people on the other side that you cannot see.

Falling from Height

When working from ladders or when cladding the steel covers, precautions should be taken such as securing ladders against the structure, supporting ladders on ground boards and using a harness if working on the cover surface. Additional care should also be taken to ensure tools or components are not dropped on to persons below.

Power Tools

Installers should be aware of the risks when using power tools on site. Power tools should be inspected and approved for safe use as required.

Packing

If the packed tank pallet is not immediately installed and you have ordered an anti-algae cover, we would recommend that the centre supporting pole is removed to protect it from very hot direct sunlight.

Suggested Safety Equipment

Good quality ladders and step ladders (various lengths), with foam protection at the base, for when working inside the tank on the installed liner.

Heavy duty plywood boards for stabilising ladders etc. on uneven ground outside the tanks (do not hang ladders from the top of tank walls, this could possibly bend the top ring of the tank).

Safety harness (for when working on galvanised steel covers).

Suitable eye protection for when using hand and power tools.

Leather safety gloves, safety boots (with soft soles for working on the liner) and hard hats.

Ear defenders for when mechanically tightening fixings or drilling outlet holes in panels.

Safety straps to secure ladders to the tank structure when working at height erecting the tank walls.



Note

For tanks with walls in excess of 3.10 metres (10ft / 4 panels high), it is recommended that platforms or mechanical lifting equipment be deployed.

In this instance, it will be necessary to ensure that the surface for approximately 2 metres all around the tank base and a suitable route to the tank base, is of sufficient quality and firmness to allow safe use of such equipment.

Options for Cushioning of the Tank Liner on the Tank Base

Option A. (Not Supplied)

To provide a 50mm layer of soft “stone free” sand to be spread evenly across the entire base within the tank structure.

To provide a 5:1 sand and cement powder “dry mix” haunch shaped to approximately 45 degrees between the inner panel wall and the concrete base floor.

Note: When providing sand, ensure it is protected from the possibility of becoming saturated by rainfall prior to its required use.

Option B. (Not Supplied)

To provide 0.80 to 1.00m wide strips of HD polythene sheeting which is taped to the tank wall and allowed to fall down on to the concrete base (e.g. half on the wall half to the base).

The 50mm layer of soft “stone free” sand is then spread over the entire concrete base and polythene sheet and shaped at 45 degrees up to the tank wall at the base of the panels.

Option C. (Supplied on Request)

Supply a quality, geotextile fleece material, layers of which would be laid at 90 degrees to each other (to eliminate gaps) on top of the sand base. Then approximately 50cm up on to the tank panels, where it would be secured to the panels with adhesive (Duck) tape.

When using EPDM liners, a double layer of fleece can be used which eliminates the use of a sand base. However the smooth concrete base must be checked for any protrusions that could potentially puncture the liner.

Wall Fleece Option

Fleece can also be provided as an option if additional protection for the liner on the internal tank wall is required, or if a small amount of insulation is required.

The use of fleece to the internal tank walls is recommended for when thinner liner materials are specified (e.g. 0.50mm and 0.60mm).

The fleece is delivered in widths of 5.25m and lengths to suit the height of the ordered tank. Lay out the pieces of fleece on the top of the tank. Work around the tank, overlapping the pieces of fleece by 25cm, until the steelwork is completely covered. Make sure that the protective fleece is straight without any creases. If you have ordered the additional protective fleece to cover the ground finally cover the floor with the protective fleece.

TANK BASE SPECIFICATION (UK full concrete base requirement)

Concrete Base can be square, octagonal or round.
 The base must be a minimum of 600mm larger than the tank diameter.
 The surface should be level over it's entire surface and be reasonably flat (smoothing not necessary).
 The finished surface must be free from any sharp protrusions, crevasses or cracks,
 which over time could cause damage to the installed Tank liner.

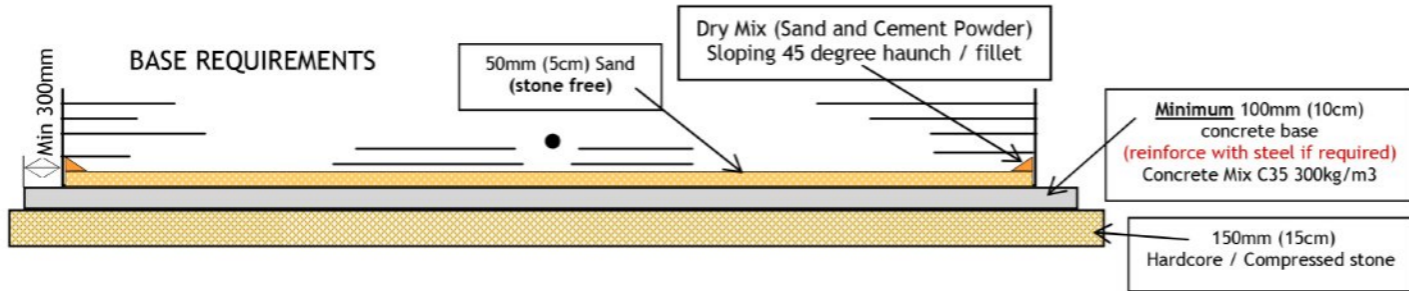

The drawing above shows the traditional method for cushioning of the liner.
 Other methods of cushioning the liner can be deployed, as advised in the storage tank installation manual.
 (eg. HD polythene sheet from the tank wall on to the base, with the sand on to the polythene sheet or the fitting of an overlapping layer of geotextile fleece, down from the tank wall across the entire tank base).

TANK BASE REQUIREMENTS			
Tank	Diameter	Minimum Base Size	Stone Free Sand Required
Metres	Feet	Metres Square/ Round/ Octagonal	Cubic Metres
2.74	9'	3.34	0.30m3
3.65	12'	4.25	0.53m3
4.57	15'	5.17	0.82m3
5.48	18'	6.08	1.18m3
6.40	21'	7.00	1.61m3
7.32	24'	7.91	2.10m3
8.23	27'	8.83	2.66m3
9.14	30'	9.74	3.28m3
10.06	33'	10.66	3.97m3
10.97	36'	11.57	4.73m3
11.89	39'	12.49	5.55m3
12.80	42'	13.40	6.44m3
13.71	45'	14.31	7.39m3
14.63	48'	15.23	8.41m3

TANK BASE REQUIREMENTS			
Tank	Diameter	Minimum Base Size	Stone Free Sand Required
Metres	Feet	Metres Square/ Round/ Octagonal	Cubic Metres
15.54	51'	16.14	9.48m3
16.46	54'	17.06	10.64m3
17.37	57'	17.97	11.86m3
18.29	60'	18.89	13.15m3
19.20	63'	19.80	14.48m3
20.12	66'	20.72	15.89m3
21.03	69'	21.63	17.35m3
21.94	72'	22.54	18.90m3
22.86	75'	23.46	20.52m3
23.77	78'	24.37	22.19m3
24.69	81'	25.29	23.94m3
25.60	84'	26.20	25.74m3
26.52	87'	27.12	25.78m3
27.43	90'	28.03	29.55m3

**Tank Ring Base (concrete ring beam—min 100mm thickness)
 (for installation on firm (stable) ground)**

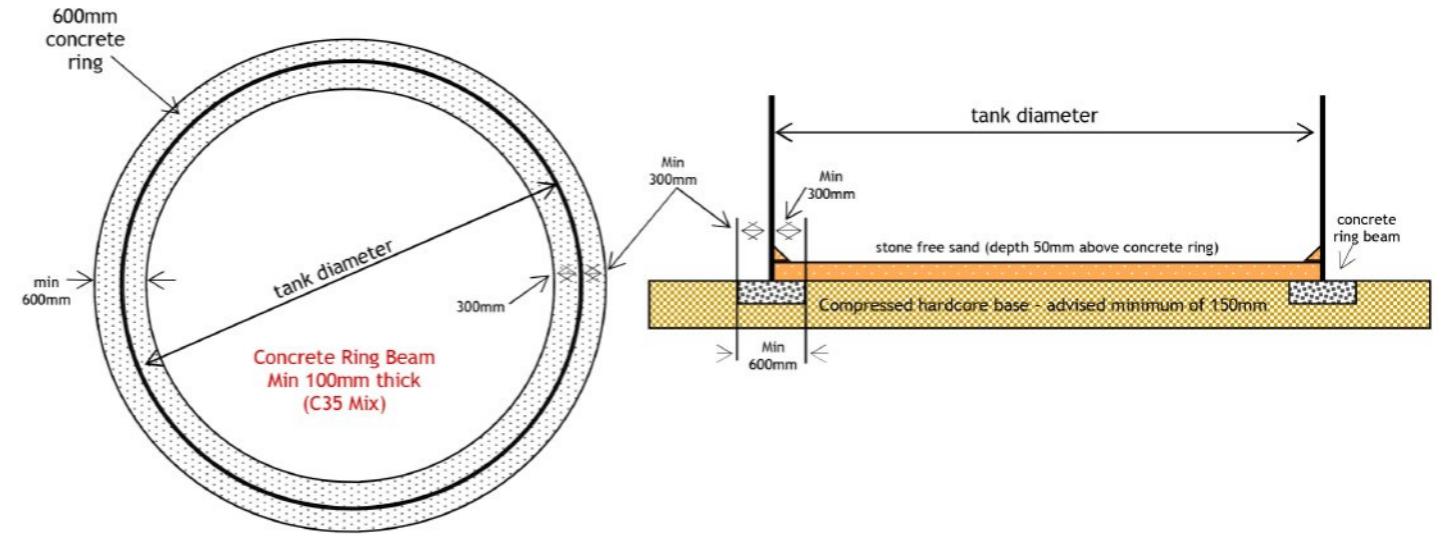

Note. For tanks to be installed where ground conditions are soft or unstable.
 The concrete ring beam should be expanded to a minimum of 1000mm in width and 150mm in depth.
 The hardcore infill may also require an increase in depth to 200mm.

SECTION B.

TANK KIT CONTENTS and TOOLING REQUIREMENTS

1: Tank Kit Contents

The tank kit contents are usually delivered strapped to a pallet and covered where possible. If the supplied kit is not to be installed immediately on arrival to site, the palletised kit should be stored undercover in a dry location, to prevent superficial deterioration of the materials and packaging.

If the supplied equipment is offloaded from the pallet on delivery, it is important that the tank panels are stored for future use in the same order as they were originally stacked on the delivery pallet. (i.e. pre-drilled panels on top followed by the thickest panels down to the thinnest panels at the bottom).

Product on the Pallet

Tank Panels – will be banded together (pre-drilled on the top followed by the thickest (base) panels down to the thinnest (top) panels at the bottom.

Note. Not all tanks have varying thicknesses of panels, some may have one thickness of panel only.

Carton / Buckets containing: Tank Fixings (M10 or M12 and M10) Tank Bolts x 20mm & 40mm, Hexagonal Nuts and Flat Washers).

Tank Erection Manual.

2: Optional items as ordered

Tank Capping

Straining Wire (coiled) + Wire Strainer

Base Anchor Brackets + Anchor Bolts

Tank Liner

(to the required size in the specified material).

Liner Repair Kit

(with EPDM liners)

Tank Outlet Assemblies

(for outlets, overflows etc)

Gate Valves

(or alternatives for the outlet assembly)

High Level Fill Valve

(Float fill valve, Float, Drop Arm).

Fill Valve Support Bracket

(for use when fitting Soft Covers)

Tank Outlet Filter Pipe

Soft Cover & Fittings Kit + PVC Support Post

Steel Pipe Work Enclosure

Protective Fleece

3: Tooling Requirement (not supplied)

Electric / Pneumatic Torque Wrench (or ratchet spanner)

Sockets (for M8 – M10 and M12 fixings) (for Torque Wrench)

Long Reach Socket (17mm) (for base bracket anchor bolts)

17mm Ring Spanner (for manual tightening)

Tape Measure (For measuring)

Large Flat Bladed Screw Driver (for holding bolt heads while tightening)

12mm Masonry drill bit (drilling for the anchor bolts)

Stilsons / Pipe Wrench x 2 (for tightening outlet assemblies etc)

H D Pliers (for cutting and winding straining wire)

Stanley Knife (Sharp – for cutting capping and possibly the liner)

17mm Podger Spanners x 2 (for hole alignment and holding panels in place)

Rubber Mallet (for tapping the capping into place)

Waterproof Adhesive (Duck) Tape 50mm (for holding capping in place etc)

Tin Snips or Hacksaw (for cutting pallet banding)

M10 Eyenut Fixings (for fitting to installed bolts to secure ladder safety straps. Supplied with Soft Covers, available as an option on other builds)

Access and Safety Equipment (as previously advised in section A.)

SECTION C.

INSTALLATION INSTRUCTIONS

1. Marking out the Base

Find the centre of the tank base then with chalk, mark out a precise circle to the advised diameter of the supplied tank. Use the marked out circle for the positioning of the tank panels.



Move the liner and liner cushioning materials into the centre of the tank (i.e sand, cement, polythene sheet, fleece etc) and protect from rainfall.

2: Un-banding the Panels

Any pre-drilled panels should be on top of the pallet. Panels drilled with outlets for the base ring should be placed in the location where the outlet is required. (Note. Any overflow drilled panels should be put to one side for later in the build).

The panels should then come off the pallet in the required numbers and thicknesses for each ring of panels, with the thickest panels at the top of the pallet being used for the bottom of the build to the thinnest at the bottom of the pallet being used for the top ring.

Each panel has an identification label which advises the steel thickness (eg 1.2) and the diameter (eg 21). The label (which is positioned in one corner of the inside of the panel) should be located on the same top edge of each panel when installing.

NOTE. Not all tanks have multiple thickness panels. Many smaller tanks are made with a single thickness of tank panel.

NOTE. On larger tank builds, some panels may have triple sets of vertical holes as opposed to the standard double sets of vertical holes. In this instance, the triple holed panels will always be installed below any double holed panels.

On standard build tanks, to confirm the number of panels per ring, take the tank diameter (in feet) and divide by 3 (e.g. 21ft tank divided by 3 = 7 panels to the ring).

3: Fixings

Washers. All fixing sets M12 or M10 are provided with 2 washers.

One washer directly against the bolt head and the second between the panel and the hex nut to the outside of the tank. The use of double washers is integral to the tank strength calculations. Not fitting double washers would invalidate the warranty. Please ensure all bolt heads are on the inside of the tank.

VERTICAL (Double or triple) seam joints (with the exception of the M10 x 40 Bolts in the Tank Base Bracket Holes), will be fitted with either M12 or M10 Fixings.

Any M12 Fixings provided should be fitted into the triple sets of VERTICAL HOLES from the base panel and panels immediately above, until the supplied amount has been used in full panel rings.

All vertical holes in remaining upper rings of panels will be fitted with the remaining M10 fixings

HORIZONTAL All horizontal holes on the ring seam joints are to be fitted with M10 fixings.

Note. Many tank builds will only require M10 fixings throughout.

4. Erecting the Steel Walls

The Base Ring Firstly select the panel / panels which have been pre-drilled to accept outlets and position as required. Then working in a clockwise direction and following the chalked circumference line, place each consecutive panel on the inside of the preceding one.

Once in position and using a podger / screwdriver to line up the holes and hold the panels in place, loosely bolt the bottom ring of panels together.

Use M12 or M10 fixings after referring to the information provided in the previous “supplied fixings” section.



Except for the single hole at the vertical seams, NO fixings are required in the bottom holes of the base panels, NOR in the top holes of the top ring. (If preferred, at the end of the panel build, any spare fixings can be installed into the redundant base holes).

The longer (M10 x 40) bolts should be used to fit the base anchor brackets (if supplied) at each seam between the base panels.

NOTE. DO NOT FIX THE BRACKETS TO THE CONCRETE AT THIS STAGE)

Once the base ring is complete and in position. Check for ovality and adjust accordingly to provide a true circle of the correct diameter (use a tape measure to double check).

Tighten a small but evenly placed number of bolts to hold the panels securely, but do not tighten all of the bolts until the tank is fully erected.



5: Erecting the upper rings

Proceed with installing the other rings of panels on top of the fitted base ring. (Check to ensure that the same or the next thickest panels are selected and used).

The exact centre of the panel for the ring above should be located directly over the vertical seam of the two adjoining panels on the ring below. (i.e. similar to a brickwork effect)

The panels should be bolted together using only the M10 Fixings with the panel above overlapping the panel below on the outside, thus enabling rainwater to run off the tank walls.

Always checking that the correct thickness of panel is selected, continue to add the remaining rings of panels but do not tighten all of the bolts until the build is completed and the tank is re-checked for ovality and re-adjusted if required.

Note. Once it becomes necessary to work from ladders and step ladders, it is important that they are made stable and fixed securely as per the H&S guidelines.



6: Final Checking and Fixing

Once all of the panel rings have been installed to the required height, double check the structure for ovality and adjust as required. (An oval tank may not accept a liner or fitted cover correctly and may result in a complete re-build of the structure)

If the circle is correct. Proceed to tighten all of the fixings on the tank and fix the Base Anchor Brackets to the concrete base.

Note. Drill and fit the bracket anchor bolt towards the front of the bracket slot and when fitting the anchor bolt, **DO NOT FULLY TIGHTEN!**

(This will allow for an amount of movement for the bracket when the water is added to the tank and any expansion has taken place).



- A. Check that there are fixings in all seam joint holes, M10 fixings on all horizontal joints and M12 or M10 on all vertical joints.
- B. Check that all bolt heads are on the inside of the tank and that any burred edges are removed
- C. Check that each ring of panels is of the correct thickness
- D. Check the fitted tank panels for any damaged or bent corners or edges. If found these must be carefully straightened back to their original profiles, to prevent puncture damage to the liner.

7: Fit the Capping

If supplied in coils, uncoil the bottom capping and straighten if possible (note. capping will be easier to fit if warmed). The capping should be fitted over the top panel edge around the entire circumference of the tank.

If supplied in lengths, capping should be fitted over the top panel edge around the entire tank.

When fitting, bend the capping back so as to open the slot. Working around the tank one person opens and applies the capping, while the other pushes or taps into place with the mallet and secures in place with adhesive (duck) tape as necessary.



8: Preparation for fitting the Side Wall Outlet Assembly

Locate the pre-drilled outlet hole in the base panel on the inside of the tank and taking one of the aluminium discs and one of the rubber gaskets supplied with the outlet assembly, proceed as follows :

Align and hold the aluminium disc over the prepared hole and secure to the panel with a tape. Then hold the rubber gasket over the aluminium disc and hold in place with small pieces of tape

(This will enable the outlet assembly to be fitted after the liner has been installed, without the need to drop the liner to fit the disc and gasket)



9: Installation and Fitting of the Liner Cushioning

Install the chosen method for cushioning of the liner on the base using one of the three methods as described on Page 5 of this manual.

- A. 50mm layer of soft "stone free" sand with a 5.1 dry mix haunch at the outer edge.



- C. A layer of geotextile fleece, taped to the tank wall.



- B. Polythene sheet from the walls to the base, with a 50mm layer of soft "stone free" sand, shaped at the edge on to the sheet. Note. Any spare fixings can be fitted into the redundant holes at the bottom of the base panels if required.



Once installed, check for evenness and to ensure there are no protrusions which could damage the liner, then move the packed liner to the centre of the tank base.

10: Unfolding and fitting the liner

Fitting the liner will require people to work inside the tank on the fitted liner surface using ladders or step ladders. It is imperative that all equipment used within the tank has been adapted to protect against damage to the liner.

This will require that ladder or step ladder feet and tops be covered with a protective cushioning material.

In addition attention should be given to the type of footwear worn when working on the liner to ensure no damaged is caused to the liner. Also ensure that carried tooling etc, cannot fall and damage the liner.

Step 1. Place the liner package centrally on the base, double check that the liner cushioning system (sand or fleece) is free from any stones or sharp object and is evenly spread across the base, finally check that footwear is clean and appropriate.



Step 2. Unwrap and roll out the centrally located liner over the prepared base. The unfurled liner ends should reach the bases of opposite walls. Unwrap the remainder of the liner carefully pulling the circular base into place, so as the base to vertical wall seam is touching the steelwork all around. When done the vertical side will then be lying flat on the base.



Step 3. Ensure that all wall seams on the liner are lifted perfectly vertically (not twisted or at an angle). The person/s within the tank should then lift the liner offering its top edge to the person on the ladder to the outside of the tank.

Lift the liner to a height when there are no folds remaining at the base ensuring that the liner remains firmly in contact with the base floor.

An all around even length of liner of approximately 12–16 inches (30–40cm) should be lifted over the tank edge and temporarily secured in place with either short pieces of the top capping or adhesive tape.

Caution: If an even all round overlap cannot be achieved, this would indicate that the tank is oval and not round! This will need to be rectified before proceeding.

Once the liner is in place, check that the overlap is even all around the tank. Then the person/s within the tank should check and adjust as required to ensure that the liner wall seams are vertical, that the liner fits closely at the base and that any remaining creases are evened out.



Note. Liner Warranty

Excessive creasing of the liner can result in early deterioration and failure of the liner. In such proven cases liner warranties become invalid.

Step 4. If supplied, straining wire and strainer should be fixed within one of the panel corrugations towards the centre of the overlapping liner and tensioned, to secure the liner to the tank.

Once the straining wire has been tensioned any excess wire should be removed.

(Note. Some types of liner may have an integral ratchet strap arrangement to secure the liner to the tank, in this case the strained wire is not required).

Step 5. If supplied, the top (1.00”) split capping should be fitted securely over the liner edge around the entire circumference of the top of the tank.

To do this, bend back the capping to open the slot, fit over the liner and panel edge and tap down using a rubber mallet and secure in place with adhesive tape as required.



SECTION D.

Galvanised Outlets 2-4"

Once the installation of the liner is completed and checked the outlet/s can be installed into the tank.



1. If the outlet includes the option of an isolation valve (e.g. gate valve, lever valve etc), then it is advised that the valve is fitted to the outlet assembly, before fitting to the tank (on steel outlets on to the short thread).
2. With the valve on the outlet tube, take one of the supplied back nuts and screw down to the base of the long thread. (Tip. If tight, tap the sides of the nuts when on the thread this should help free the nut and enable it to run more easily down the thread). Next slide one of the supplied aluminium discs down to the fitted back nut.
3. From the outside of the tank, offer up the long thread with fitted nut and disc, through the pre-drilled outlet hole and carefully through the pre-fitted aluminium disc and rubber gasket, which was previously taped in place between the inner tank wall and the liner.
4. Whilst the person outside the tank holds the outlet assembly upright and very firmly, (taking care not to dislodge the internal disc and gasket) the person on the inside of the tank (after ensuring that the liner is correctly positioned,) carefully uses the face of the rubber mallet to gently tap out a neat circle of liner material using the end of the outlet tube as a cutter. (Note. If knives are used to cut outlet holes, extreme care should be taken, as any damage caused may invalidate the liner warranty).
5. Once the outlet tube is cleanly through the liner wall, firmly push the second rubber gasket down on to the liner followed by the final aluminium disc and finally thread the second back nut to tighten against the aluminium disc (hand tight only).
6. Finally after checking that the liner is free from creases between the discs and gaskets, with one person holding the inside back nut firmly with stilsons, a second pair of stilsons is used to carefully tighten the outside back nut, ensuring that the outlet thread does not rotate as this may cause the liner to distort and tear.

(Tip. If an outlet assembly should require tightening, this should always be done from the inside of the tank, so as to ensure that the liner does not get twisted or torn)

This should now complete the installation of the liner.

Tank Outlets & Overflows

Side Tank Outlet Assembly- Flanged for tanks 21ft / 6.40m diameter and larger

(available in galvanised or uncoated steel in sizes 5"/125mm, 6"/150mm, 8"/200mm, 10"/250mm and 12"/300mm - imperial or metric flanges)

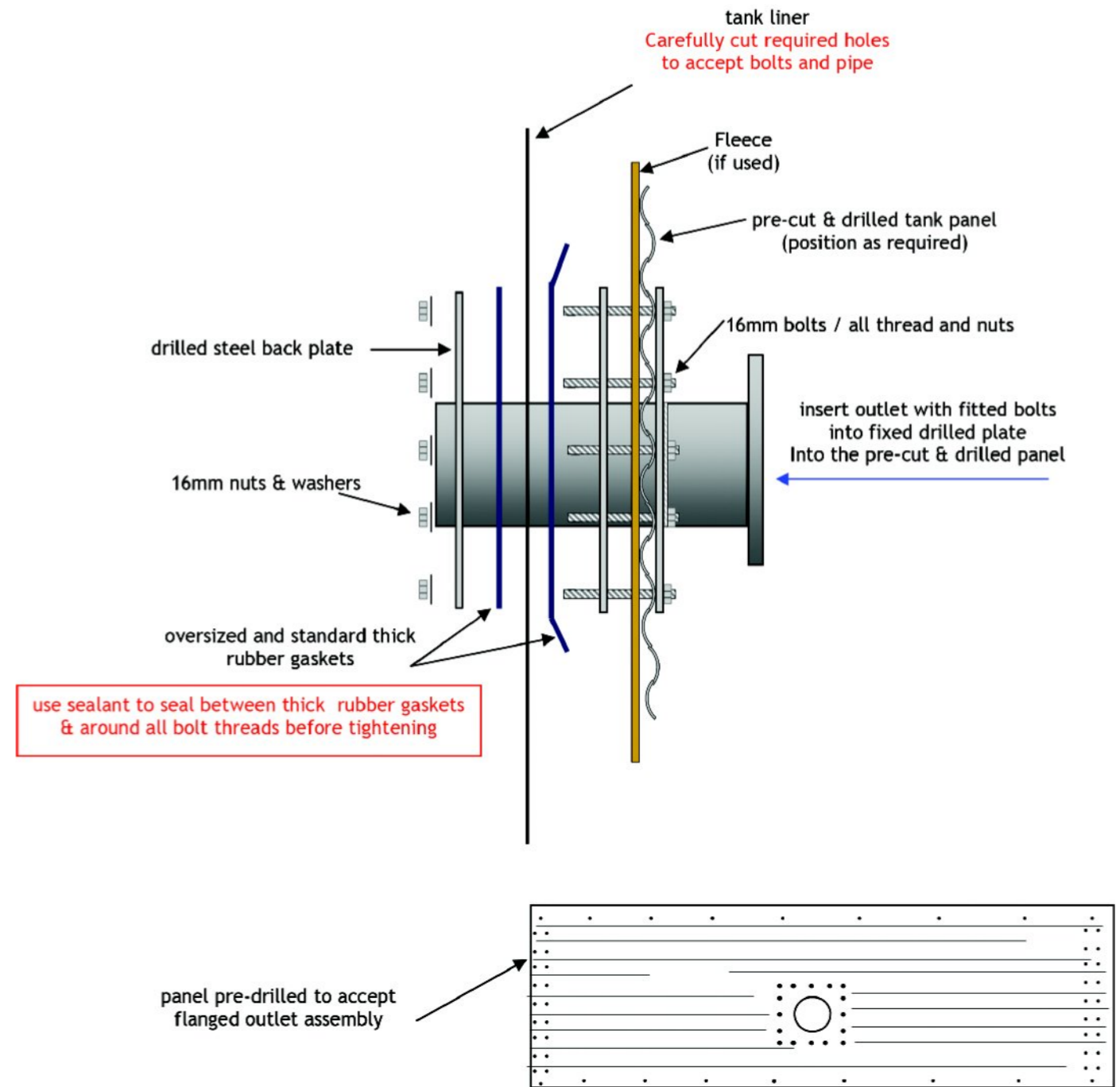

Note. Due to the curve of the panels, the flanged outlet assembly is not available for diameter tank sizes below 21ft / 6.40mts.

Installation of Flanged Tank Outlets

TO15GFL (125mm) TO16GFL (150mm)
TO18GFL (200mm) TO20GFL (250mm)

A) Preparing the liner

1. Pre-hang the liner ensuring the seams are vertical and that the liner around the outlet hole is free of creases
2. Offer the outlet pipe through the hole in the panel up to the liner, ensuring it is held at right angles to the panels.
3. Mark the position of the tube end on the liner before carefully cutting a hole in the liner approximately 1" smaller than the tube end.
4. Fit the long threads and nuts to the first (welded) plate on the outlet, offer the pipe up to the panel locating and inserting the long threads through the small holes.
5. When held in position carefully push the liner over the tube to a point where the long threads are against the liner, carefully mark and cut out the holes for the bolts in the liner.
6. When all of the holes have been cut, the outlet is ready to install.

B) Installing the Outlet

1. Drop the liner away from the tank wall and lift the outlet into position, placing the tube and the long threads through their appropriate holes.
2. With the outlet being supported on the outside of the tank, the assembly of the outlet is now done from the inside of the tank.
3. Add the first of the steel plates (pre-threaded) over the tube and screw in the long threads, followed by the larger of the rubber gaskets.
4. Apply mastic to the rubber gasket around each of the threads and in a circle around the large hole (approximately 1" / 2.5cm)
5. Carefully fit the liner over the tube and the long threads ensuring it is free from creases.
6. Add mastic in a ring around the long tube onto the surface of the liner and also around all of the long threads.
7. Fit the smaller of the rubber gaskets and press to fit against the liner.
8. Add the final steel plate, the hexagonal nuts and tighten with a spanner. As tightening takes place, remove excess mastic with a damp cloth as it is squeezed from the seals.
9. Continue to tighten the bolts until all of the components are pressed together as tight as possible (this may require the tightening of each bolt several times)
10. Finish fitting and securing the liner in the standard way.

C) Checking and Filling

Checking

Before adding water to the tank, it is essential to make the following checks:

Check that the liner is positioned correctly and that the base seam has not moved away from the wall. Re-adjust as required, to ensure "bridging" will not occur when water is added.

Check that all tooling etc has been removed from the tank.

Inspect the liner base and the walls for any possible damage caused by ladder feet or dropped tooling etc.

If damage is found, make the appropriate repairs with the provided emergency repair kits, following the manufacturers provided instructions.

Note. EPDM (rubber) or PVC materials require a glued patch repair. FPP (polypropylene) material requires a specialist applied heated patch method. (Details on request).

Filling

Add 50 to 75mm of clean water to the tank then re-check the liner fit around the entire circumference.

Flood the tank to an approximate 150mm depth of water

(Note. This is the minimum amount of water required to ballast the liner, if the tank is not due to be filled immediately).

Check that the anchor brackets bolts are not fully tightened down to the concrete base, so as to allow the bracket to release so it is able to slide out if needed. (Once the tank has been filled, the anchor bracket bolt can be fully tightened if required).

Check for leaks at the outlet. If leaking, re-check the liner position to the internal rubber gaskets to ensure there is no twisting or pinching of the liner and from the inside, tighten a little more if required

Note. Water on the base does not necessarily indicate a leaking tank!

If using sand beneath the liner, the weight of water in the filled tank will squeeze any moisture out of the sand. This will show on the outer concrete base for a week or two before the sand dries completely.

Finally, ensure that care is taken when removing ladders, equipment and personnel from the inside of the tank, to avoid causing damage to the liner or tank wall structure.

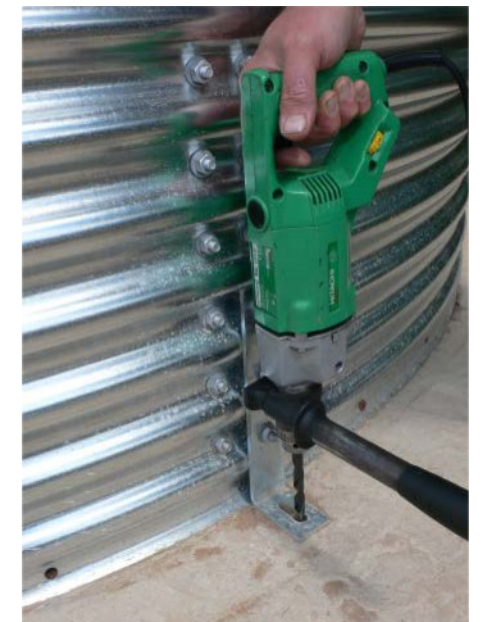

2 Top Hat / Witches Hat - Base Outlet System
(sealed to the liner and outlet pipe)

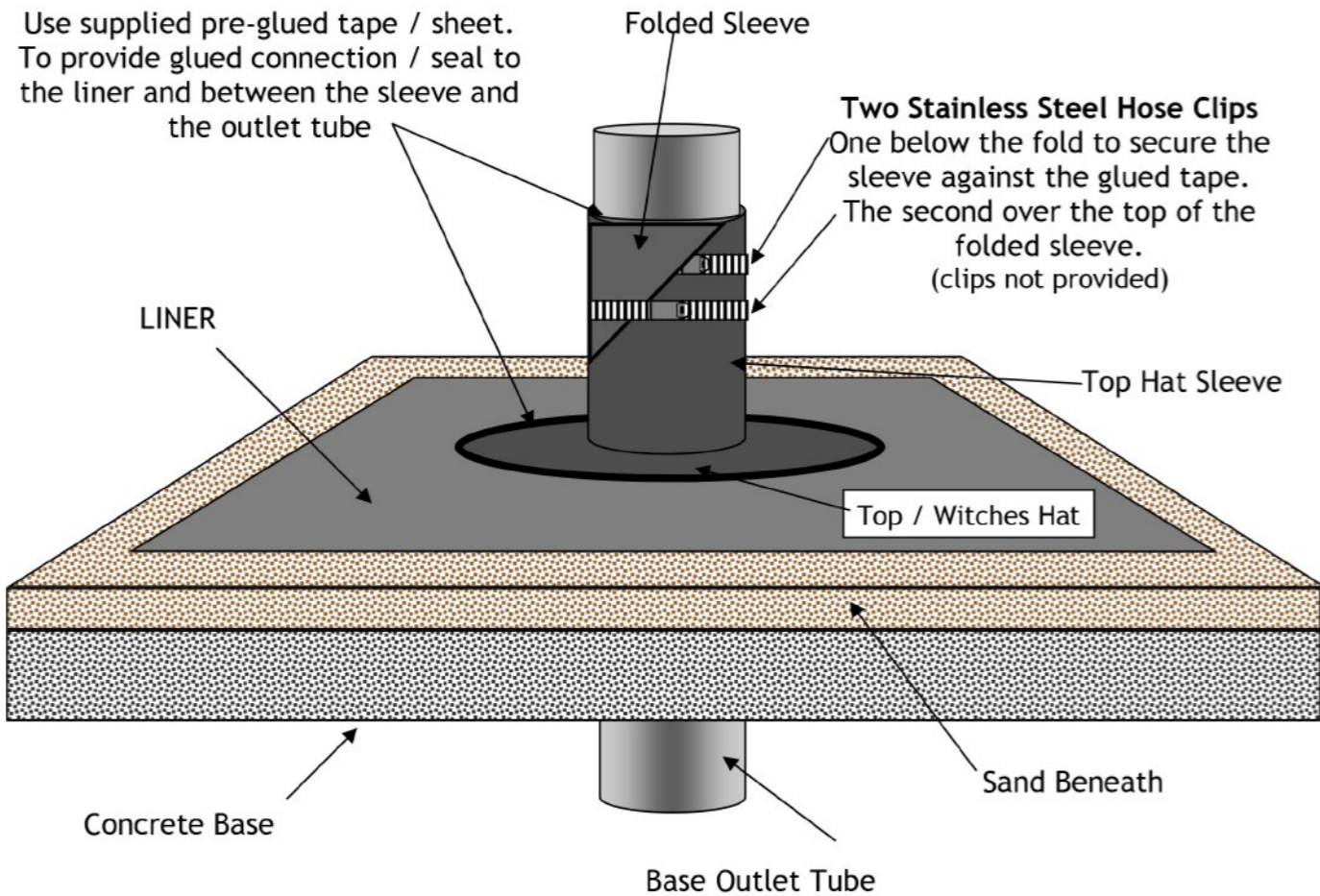

Use supplied pre-glued tape / sheet.
To provide glued connection / seal to
the liner and between the sleeve and
the outlet tube

Folded Sleeve

Two Stainless Steel Hose Clips
One below the fold to secure the
sleeve against the glued tape.
The second over the top of the
folded sleeve.
(clips not provided)

Top Hat Sleeve

Top / Witches Hat

Concrete Base

Base Outlet Tube

Sand Beneath

Liner Repair Product

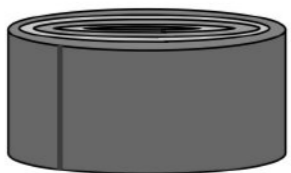

Double Sided, Glued Repair
Tape or patch sheet

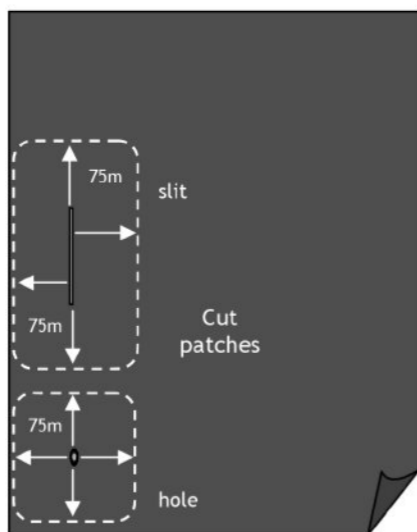

Stainless Hose Clips Not Supplied

**3 EPDM (SCGT)
LINER REPAIR KIT**

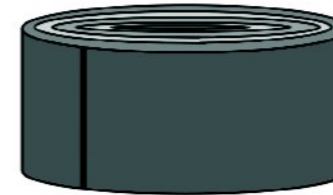

Contents:
**Double Sided, Glued Repair Tape
and
Patch Repair Sheet**

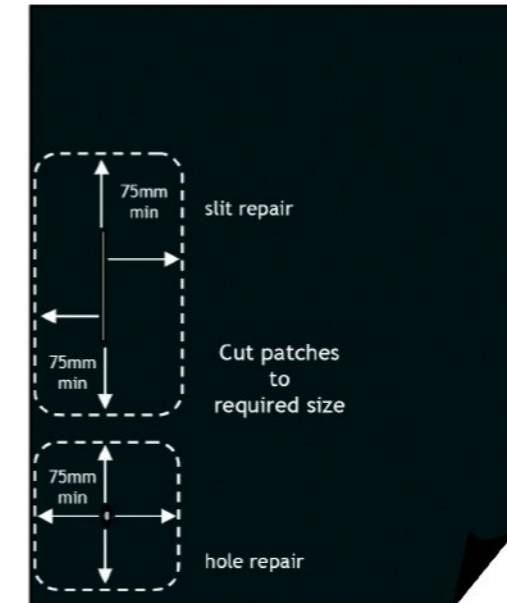

IMPORTANT !
This repair system is only suitable for the patching of small holes or splits and which are not found on the welded liner seams.

Liner Repair Method

A. After locating and marking the position of the hole or cut in the liner.
Firstly ensure that the surface immediately around the damaged area of liner, is clean, dry and free from grease or slime etc.

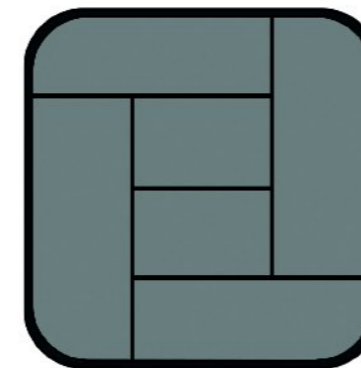

B. Prepare the required size of repair patch from the provided sheet, then fix the repair tape over the entire surface of the patch.

Round off the corners of the prepared patch, to help prevent the patch corners from peeling.

Tip. If making repairs to a new, unused liner, prepare two patches and fix one to each side of the damaged liner.

C. On a firm, flat surface.
Apply the repair patch to the prepared area of liner, ensuring that the patch fully covers the located hole or split in the liner.

D. Using a hard surfaced roller.
Rolling back and forth, apply a firm downward pressure over the taped patch, to compress the whole of the repair patch firmly on to the liner.

Repeat the process if fitting a second patch, To the other side of the liner.

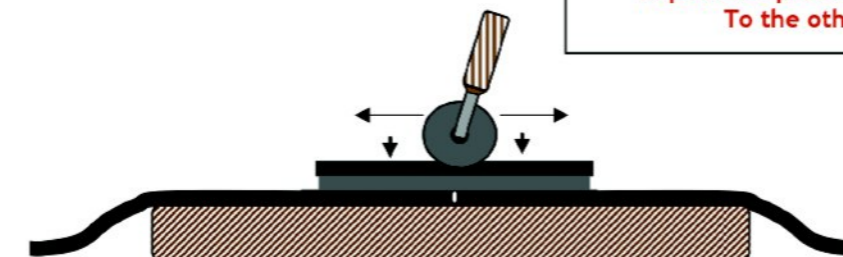

TLREPD repair

4 ENPEX FPP LINER REPAIR KIT

Contents:
Heat Gun, Hand Roller, Scissors
And Repair Sheet

Liner Repair Method

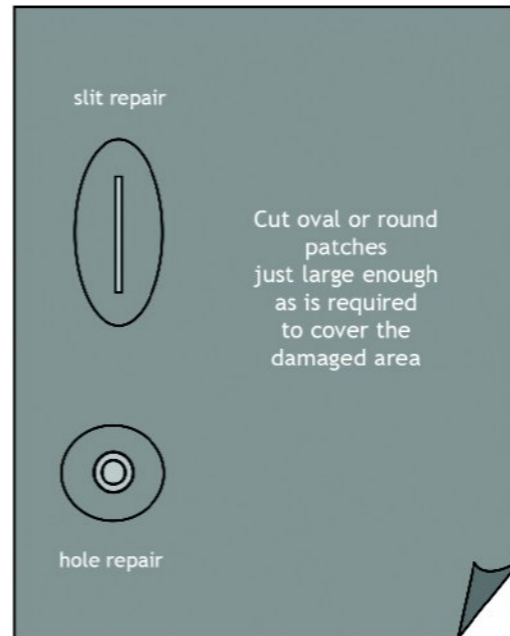

A. After locating and marking the position of the hole or cut in the liner. Firstly ensure that the surface immediately around the damaged area of liner, is clean, dry and free from grease or slime etc.

B. Prepare the required round or oval size of repair patch from the provided sheet.

With the liner supported on a firm flat surface, position the repair patch over the damaged area and hold in position with the hand roller.

When the heat gun has reached the required temperature, carefully slide the flat nozzle on the heat gun under one edge of the patch for a few seconds and remove, before firmly applying pressure with the roller to weld the two surfaces together, then repeat the same action to the other edges of the patch.

Finally, with a finger nail, check that all edges are welded down and if any lift, apply a little more heat and hand roll to complete the sealing.

Caution. Do not overheat the liner material

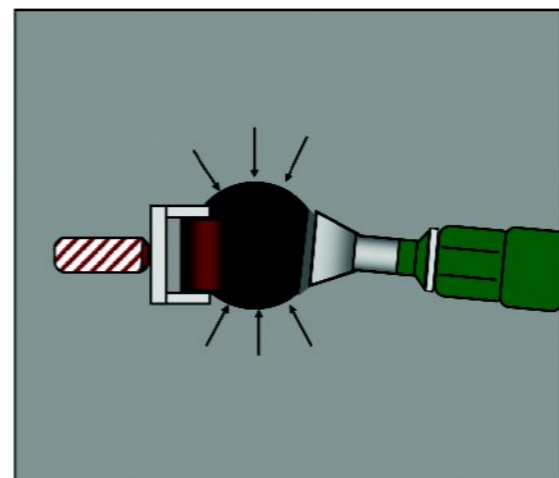
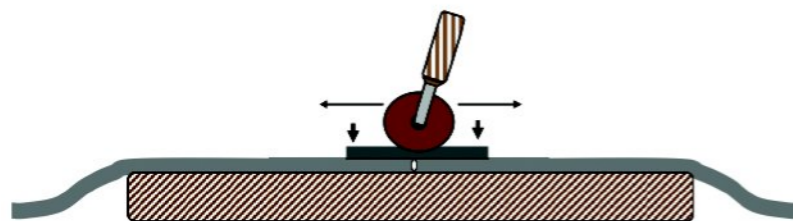

Tip. Searching for and locating leaks in liners
One person to be behind the liner (in the dark!), with a second person shining a torch at the suspect area of damaged liner.

The person in the dark should be able to identify and chalk mark the exact damage location from the pinprick of torch light showing through the liner material.

FLEECE EXAMPLE IN STORAGE TANKS 24/4 AND 24/6

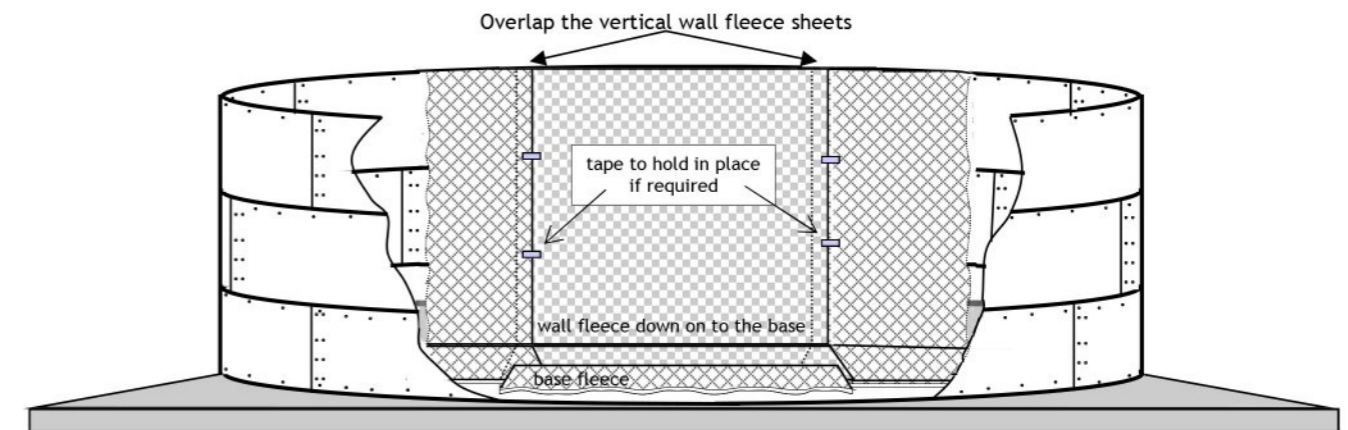

Keep the number of folds in the fleece to minimum

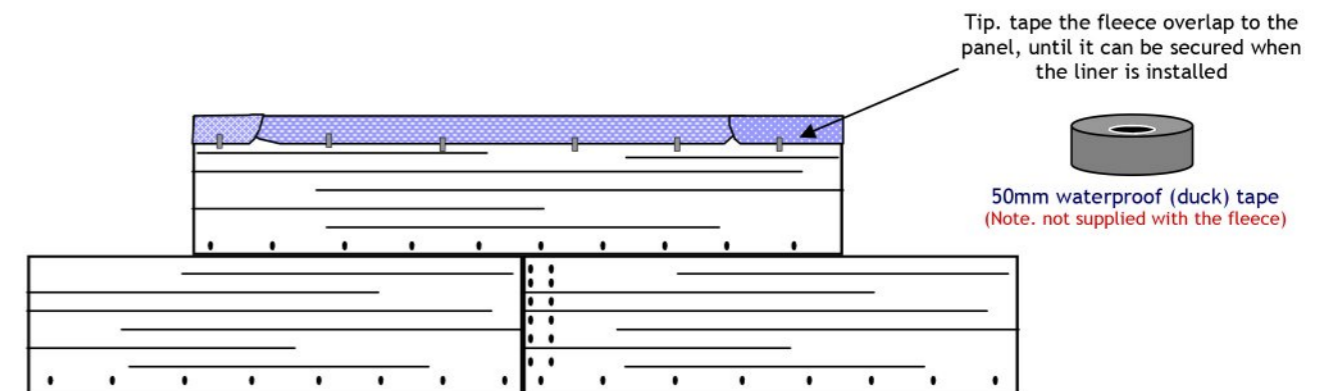

The tank base surface should be level and flat with a reasonably smooth finish and no exposed sharp protrusions

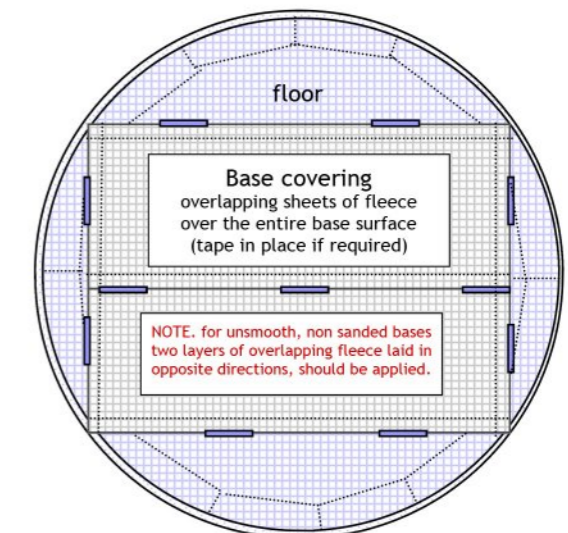
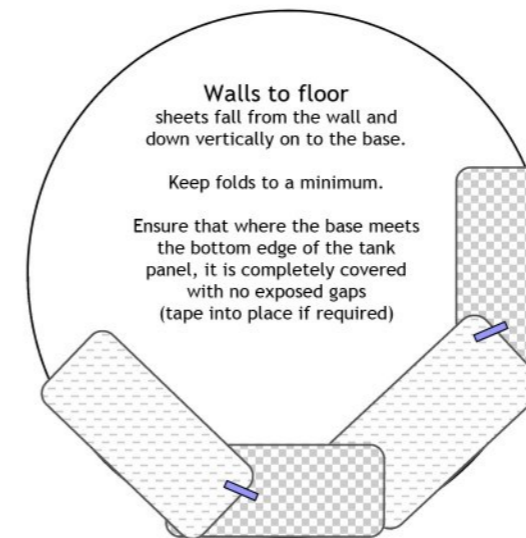

Note. If fitting base fleece only.
Ensure that the fleece is taken from the tank wall and down on to the base, ensuring there are no exposed areas where the panels meet the base.
(tape in place as required)
(If possible, add a cushioning bank of sand all around the panel to base corner, beneath the fleece)

F: Storage Tank Maintenance

Tank Base and Surrounds

Make regular inspections to ensure that the concrete base has not been damaged or is suffering from concrete degradation, also maintain clean and clear access all around the tank to allow for any future maintenance of the structure.

Tank Steel Structure

Avoid damage to the galvanised steel structure and any attached pipe work by ensuring that vehicles or mechanical lifting equipment cannot come in direct contact with the tank (fork lift trucks and pallets etc). Regularly check the outlets and isolating valves to ensure they remain in good working order.

Tank Cover and Internal Fill valves etc. (if supplied)

Check annually, the tension of the steel tie down straps and tighten if required.

Remove the appropriate access hatch cover and make regular checks of any installed water feed valves to ensure that the valve is opening and closing correctly at the right water fill levels.

Any debris or pooled water should be removed from the tank cover as soon as possible, failure to do so could put substantial pressure on the cover support structure and cause damage to the top ring of the tank. Check the centre support pole on a regular basis to ensure this has not moved. Please ensure this has been done after any periods of high wind activity.

When using a Floating Cover, especially in windy conditions, the liner should be inspected at regular intervals for wear and tear. Dropping the water level may be a good precaution in certain conditions.

Important! Ensure that when working at high level, hatch covers and tools etc, are secured so as to prevent possible damage and injuries from falling objects.

Working Within the Storage Tank

For safety reasons, if it is necessary to enter the tank, always ensure that a responsible person supervises from outside the tank until such times as the tank has been vacated. Note: the tank will constitute a Confined Space and appropriate precautions should be taken.

Warning! Do not enter the tank until the water has been emptied to a safe working level.

Drain the tank via the installed tank outlet (utilise the pump system if possible). Then if required, remove the remaining water with a submersible (sump) pump and attached hose, either out through an open outlet or over the rim of the tank.

Important! If working inside the tank. To prevent damage to the lining material, ensure that ladder/step ladder feet are cushioned, that only soft soled shoes are worn and that components or tools etc, are held securely and cannot fall and pierce the liner.

The covered tank, if filled with mains water or filtered re-cycled water, should not accumulate debris or silt on the liner base. Should the tank be filled from other sources (bore-hole, well, stream etc), it is possible that silt etc, may eventually settle and build up on the liner.

Important! Do NOT attempt to remove any accumulated silt or debris the bottom of the tank with manual tools (rakes, shovels etc), as this will almost certainly pierce the lining, resulting in an expensive re-fit and possible damage to the surrounding areas from water spillage.

Remove silt etc, by suction or with a submersible pump.

Winterisation

Generally, water within a covered storage tank with an automated fill arrangement, and which is in regular use, will not freeze sufficiently to cause damage to the structure.

For tanks with no winter usage, the tank can be drained to a low level.

For tanks with no winter usage, likely to experience temperatures below -10 Celsius, the tank can be completely drained and the liner weighted with sandbags every 1.5m².

Important! An empty tank structure is considerably less stable, especially if exposed to strong winds.

For special tanks which have to remain full for emergency use (fire tanks etc), it is advised that internal immersion heating is installed in the location of the fill valve. This is to ensure icing does not occur under the fill inlet.

Where temperatures may fall below -10 Celsius, electronic or mechanical accessories (e.g. depth gauge, immersion heater) should be removed and stored.

Feed pipe work, external valves and delivery hoses to pump rooms etc, should be lagged to protect from possible freezing wherever possible.

As a minimum, an annual inspection of all tank components should be undertaken to validate the warranty.