

## Mini Monster

Submersible Cutter Pump

## Product Overview

The Mini Monster has been specifically designed for applications where larger solids are commonly discarded into the waste sewage system.

The Mini Monster easily slices through wastewater solids and fibrous materials with its high-torque tungsten edged impeller, which would normally cause issues for a standard pump station.

This system is ideal for applications such as care homes, bars and restaurants, retail outlets, caravan sites, and other commercial properties. It can also be used in the following applications:-

- ▶ Sewage
- ▶ Storm and water drainage
- ▶ Wastewater
- ▶ Commercial buildings
- ▶ Restaurants, hospitality, and nightclubs

## Features and Benefits

The Mini Monster comes with a range of industry leading features to ensure a long lifespan and next level performance.

- ▶ Non clog operation with cutting action
- ▶ EKK Eagle Burgmann double mechanical seal CA/CE & SIC/SIC
- ▶ Built-in motor protection
- ▶ Tungsten Edge hardness is 89HRA
- ▶ Volute 4 inch connection available in JIS 10K, ANSI 125/150 and PN10/16
- ▶ Adjustable clearance construction to maintain performance

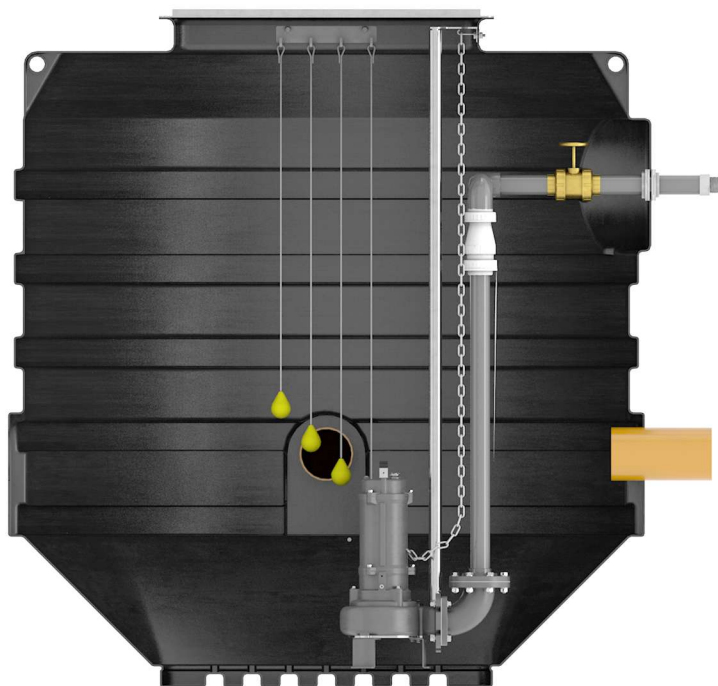
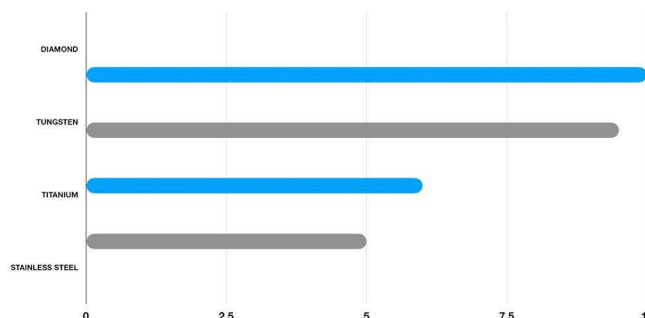

DIAMETER	HEIGHT	CAPACITY
1500mm	1500mm	2600L
1500mm	2000mm	3500L
1500mm	2500mm	4400L
1500mm	3000mm	5200L
1800mm	2000mm	5000L
1800mm	2500mm	6000L

**Twin pump option also available**

# Mini Monster Features at a Glance

**ROBUST MDPE CHAMBER**

**NON-RETURN VALVE  
ARRANGEMENT AS STANDARD**



**MINI MONSTER CUTTER**



**Twin pump option also available.**

## Pump Curves

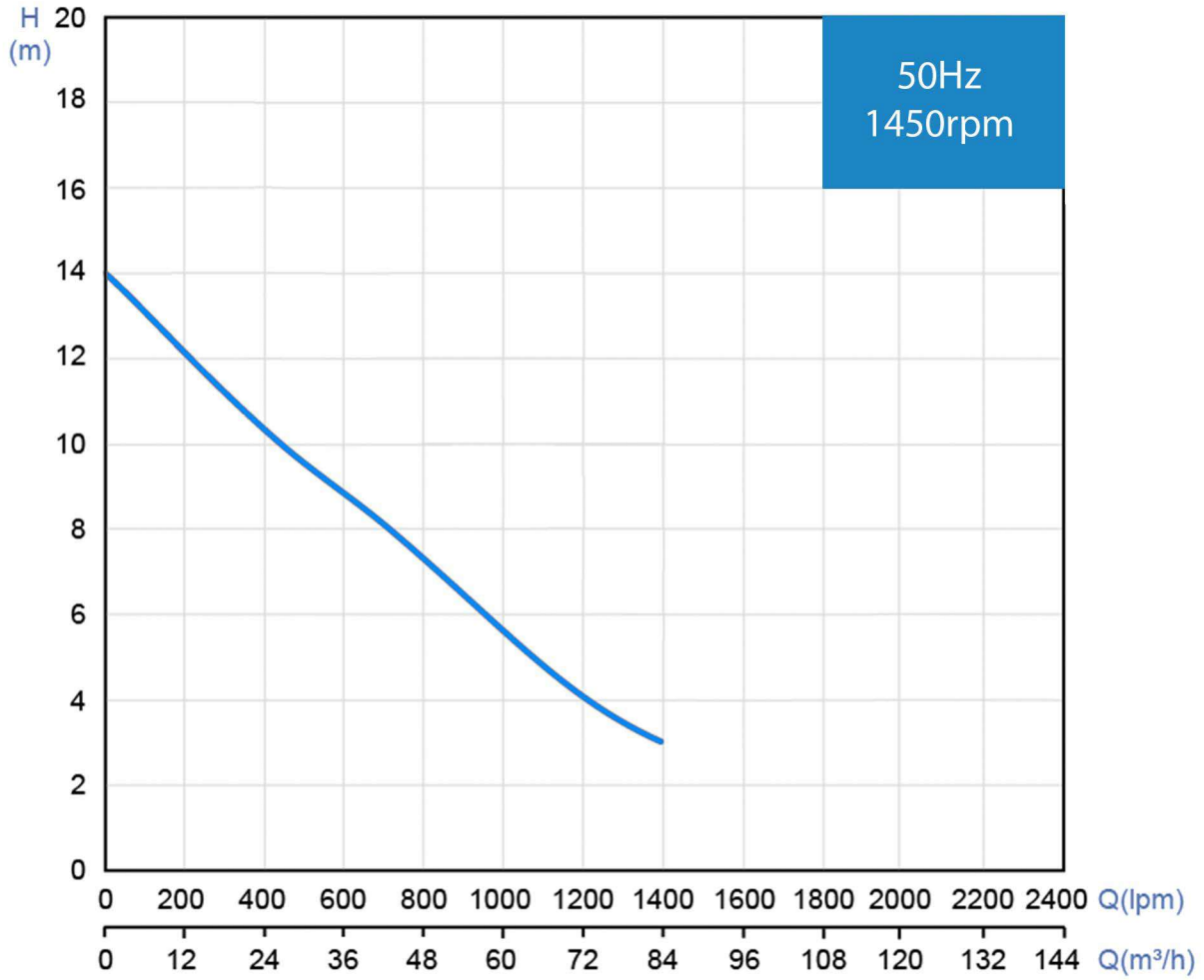

		Description	Detail
		Liquid Temperature	0-40°C (32-104°F)
		Submersible depth	10M
Motor Part	Frequency	50Hz	
	Pole	2 Pole	
	Type	Dry Type	
	Insulation	50Hz: 1.5-3HP Class B ; 5-7.5HP: Class F	
	Protection	IP68	
	Protector	Auto-Cut	
Pump Part	Bearing	Ball Type	
	Mechanical Seal	Double Mechanical Seal	
	Impeller	Semi-open Impeller	

## Example Installation

NUMBER	DESCRIPTION
1	Bathroom where fibrous waste is deposited
2	Inlet to the Mini Monster chamber
3	Mini Monster Pumps (Single and Twin options)
4	MDPE chamber
5	Outlet to sewer

\*This is an example layout and is not representative of a specific project





Direct Pumps and Tanks Ltd  
Unit 12 Cossall Industrial Estate  
Ilkeston  
Derbyshire  
DE7 5UA  
Tel: 0115 9444474  
Email: [info@dandt.co.uk](mailto:info@dandt.co.uk)