

AQUABOOST

SP1V-10HM06S-VARiFLO-8

The Aquaboost SP1V-10HM06S-VARiFLO-8 booster set utilises WRAS approved components* and features a stainless steel multistage pump. The pump is operated by our advanced variable speed controller and will deliver a nominal flow rate of 10 m³/h and nominal head pressure of up to 5.4 bar.

*WRAS & KIWA Regulation 4 approval pending



Features

- Flow rates up to 14 m³/h
- Head pressure up to 7.2 Bar
- Variable speed pump control
- Full WRAS & KIWA Regulation 4 approval pending
- 304 Stainless Steel pump
- 304/316 Stainless steel manifold assembly
- 8 litre pressure vessel with flow through isolation & drain valve
- Air cooled inverters
- BMS Volt free contacts
- External Low Water
- Electronic dry run protection
- Base mounting, Suction Fittings, AV mounts & Flexible connectors optional

Applications

- Cold water pressure and flow boosting in a range of domestic, commercial and industrial applications

Product Code Structure

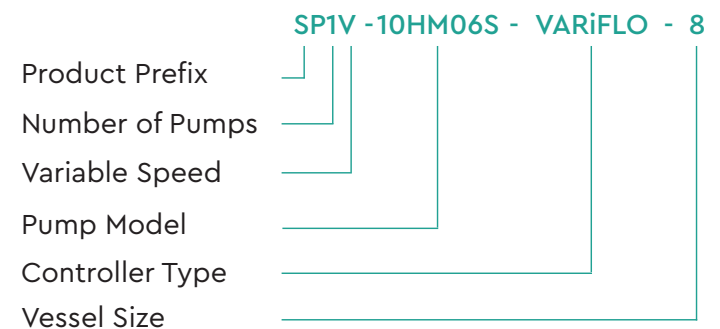

Pump Characteristic SP1V-10HM06S-VARiFLO-8

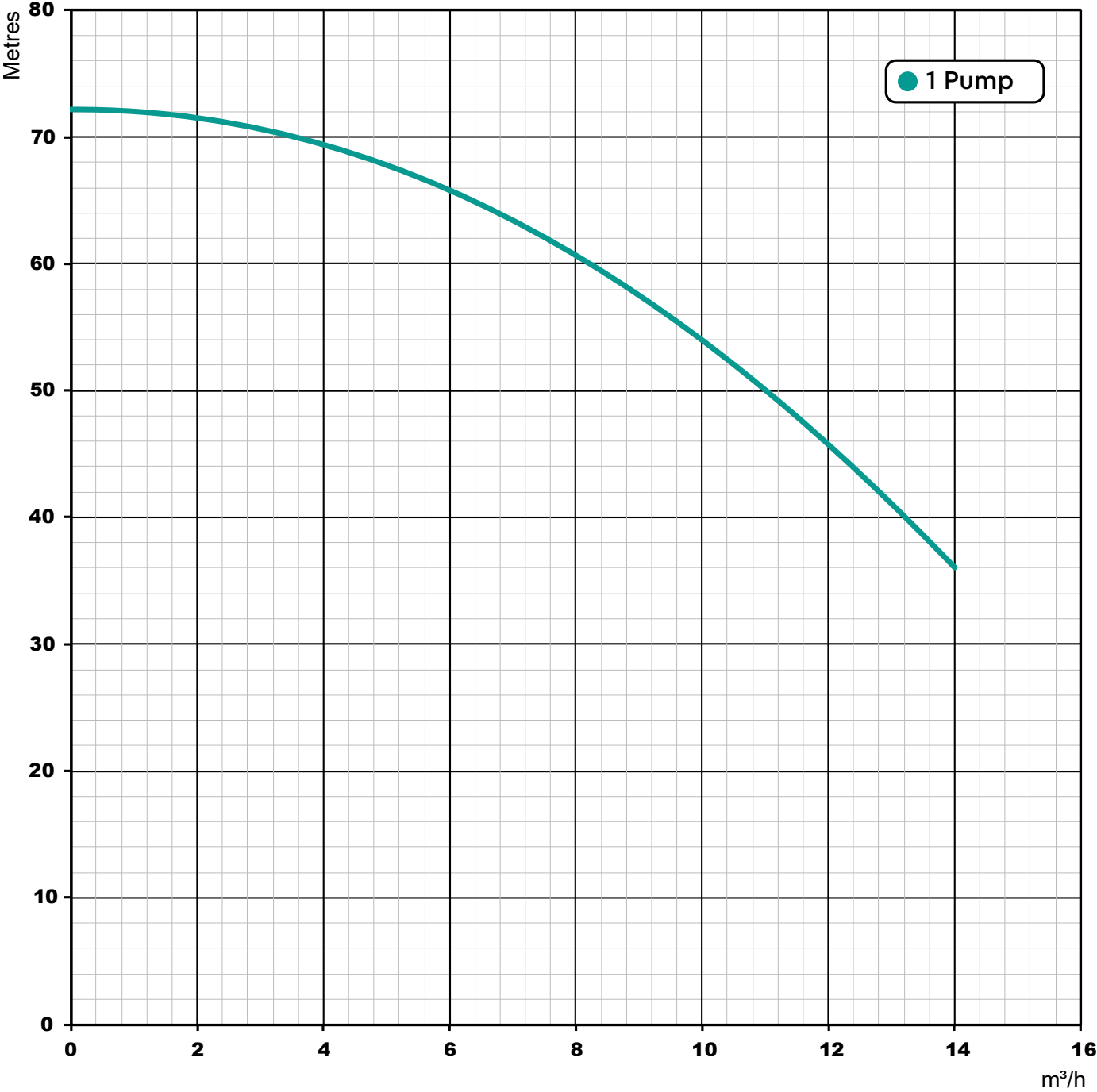

Aquaboost Model		SP1V-10HM06S-VARiFLO-8 62019
General	Warranty	2 Years
	WRAS approval	Pending
	Conformity certification	CE / UKCA
Features	Dry run protection	✓
	Glycerine filled pressure gauge	✓
	Pump check valve(s)	✓
	BMS volt-free contacts	✓
Performance	Nominal head	5.4 bar
	Maximum head (closed valve)	7.2 bar
	Nominal flow rate	10 m ³ /h (per pump)
	Maximum flow rate	14 m ³ /h (per pump)
	Minimum static inlet pressure	1 metre
	Maximum static inlet pressure	10 metres
	Maximum ambient air temperature	Max 40 °C
	Water temperature range	Min 4 °C / Max 23 °C
	Maximum working pressure (kPa / bar)	1000 kPa / 10 bar
Connections	Inlet	1-1/2" BSP
	Outlet	1-1/4" BSP
Manifold	Manifold construction	Stainless steel
	Pump isolation valves	Full bore, lever
Pump	Number of pumps	1
	Pump type	Multistage centrifugal (horizontal)
	Pump body	Stainless steel
	Impeller	Stainless steel
	Mechanical seal	EPDM / Silicon Carbide / Carbon
	Motor type	Induction (current overload sensor)
	Duty rating	Continuous (S1)
Electrical	Power supply / phase / frequency	230 V / 1 / 50Hz
	Power consumption	2.2 kW
	Current - full load	8.6 Amps
Physical	Enclosure protection	IP55
	Width	271 mm
	Depth	595 mm
	Height	825 mm
	Weight	35 kg

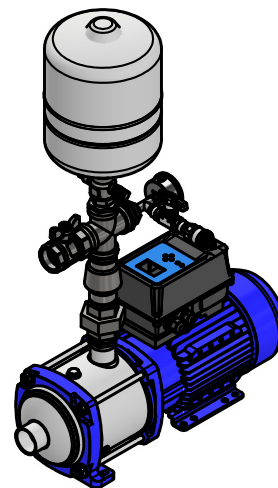
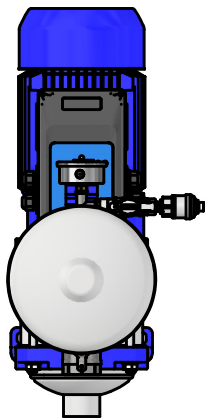
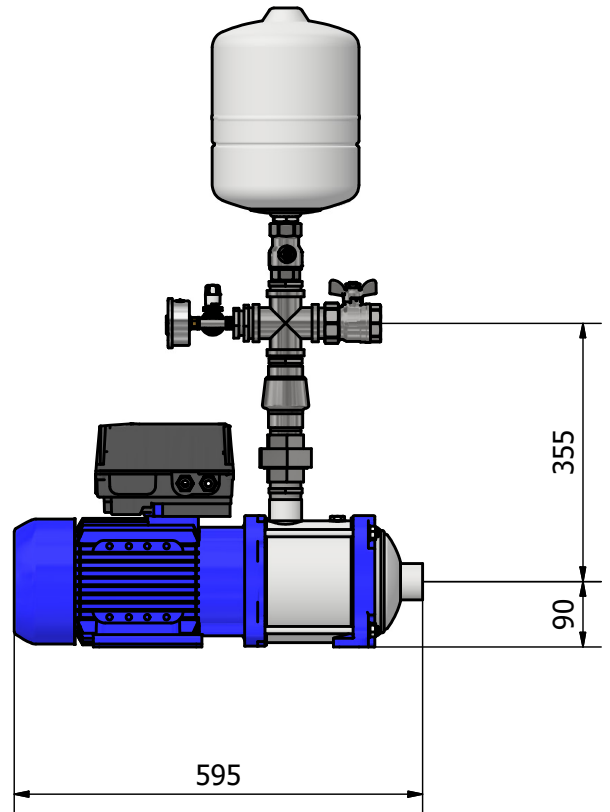
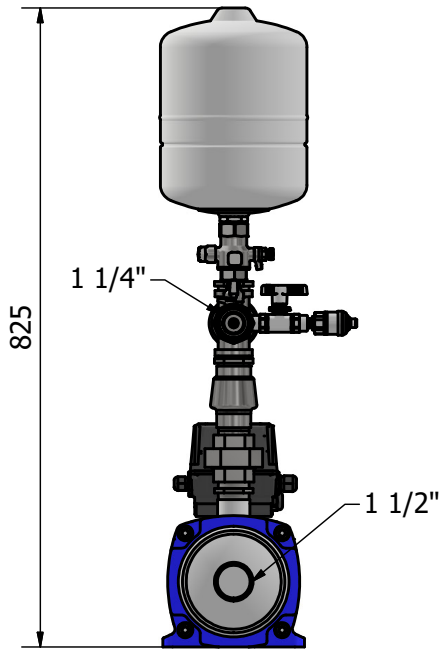

Stuart Turner Limited reserves the right to amend specifications without notice.

Stuart Turner Ltd, Henley-on-Thames, Oxfordshire RG9 2AD Tel: +44 (0) 1491 572655 Fax: +44 (0) 1491 573704
TechAssist Helpline +44 (0) 800 31 969 80
www.stuart-turner.co.uk

Model No. SP1V-10HM06S-VARiFLO-8 Issue 4222-01-02