

AQUABOOST

SP1V-3HM08S-VARIFLO-8

The Aquaboost SP1V-3HM08S-VARIFLO-8 booster set utilises WRAS approved components* and features a stainless steel multistage pump. The pump is operated by our advanced variable speed controller and will deliver a nominal flow rate of 3 m³/h and nominal head pressure of up to 4.7 bar.

*WRAS & KIWA Regulation 4 approval pending



Features

- Flow rates up to 4.4 m³/h
- Head pressure up to 6 Bar
- Variable speed pump control
- Full WRAS & KIWA Regulation 4 approval pending
- 304 Stainless Steel pump
- 304/316 Stainless steel manifold assembly
- 8 litre pressure vessel with flow through isolation & drain valve
- Air cooled inverters
- BMS Volt free contacts
- External Low Water
- Electronic dry run protection
- Base mounting, Suction Fittings, AV mounts & Flexible connectors optional

Applications

- Cold water pressure and flow boosting in a range of domestic, commercial and industrial applications

Product Code Structure

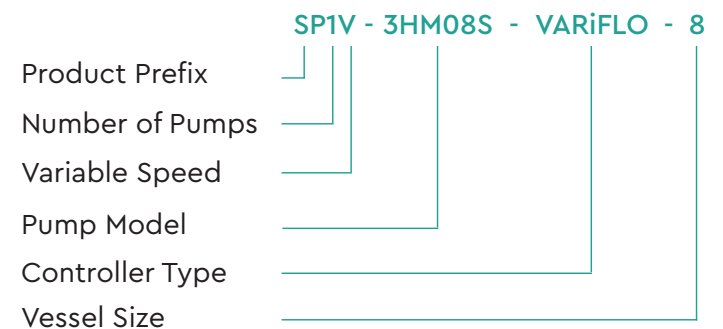

Pump Characteristic SP1V-3HM08S-VARiFLO-8

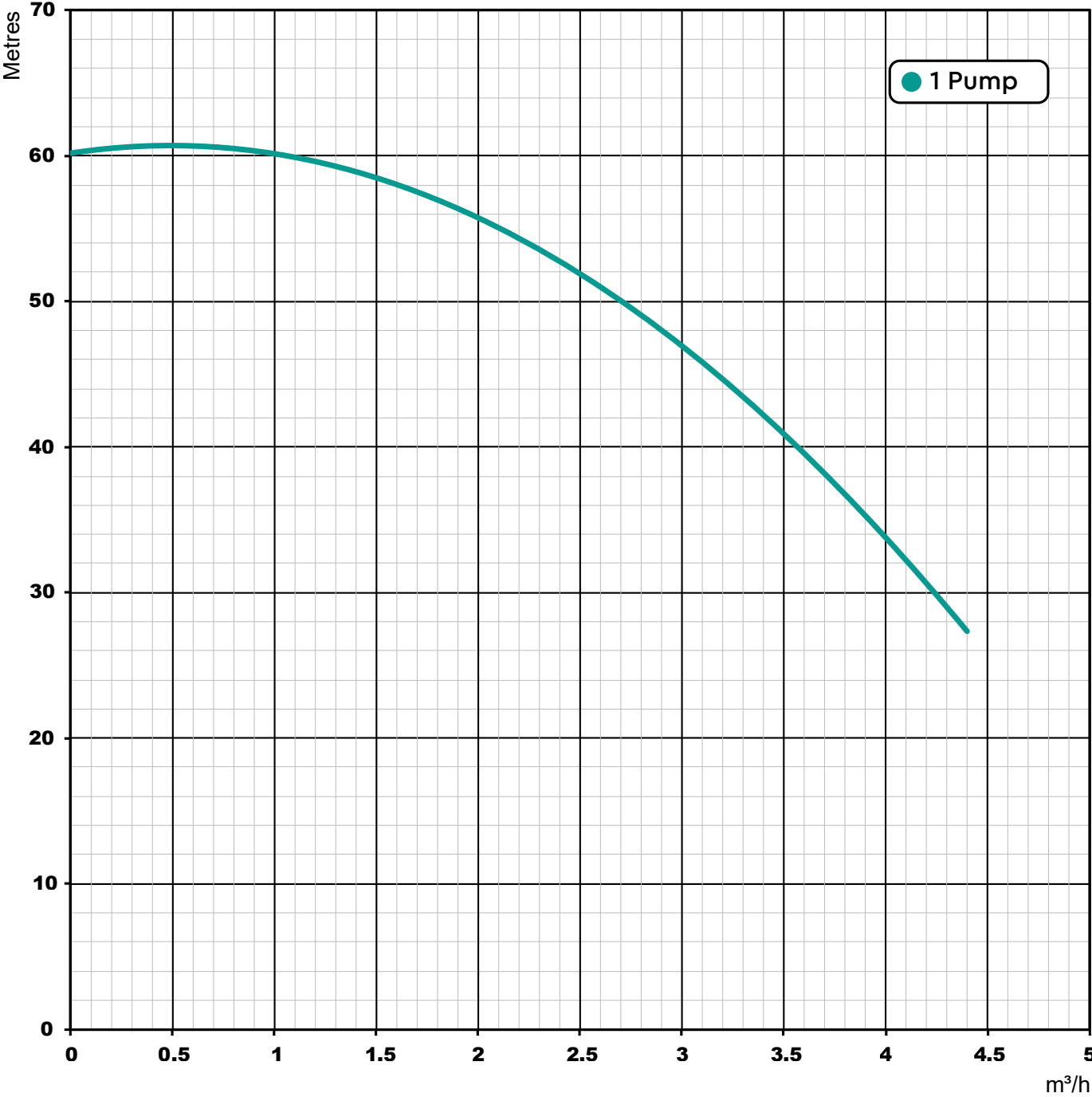

| Aquaboost Model | | SPIV-3HM08S-VARiFLO-8 62009 |
|-----------------|--------------------------------------|-------------------------------------|
| General | Warranty | 2 Years |
| | WRAS approval | Pending |
| | Conformity certification | CE / UKCA |
| Features | Dry run protection | ✓ |
| | Glycerine filled pressure gauge | ✓ |
| | Pump check valve(s) | ✓ |
| | BMS volt-free contacts | ✓ |
| Performance | Nominal head | 4.7 bar |
| | Maximum head (closed valve) | 6 bar |
| | Nominal flow rate | 3 m ³ /h (per pump) |
| | Maximum flow rate | 4.4 m ³ /h (per pump) |
| | Minimum static inlet pressure | 1 metre |
| | Maximum static inlet pressure | 10 metres |
| | Maximum ambient air temperature | Max 40 °C |
| | Water temperature range | Min 4 °C / Max 23 °C |
| | Maximum working pressure (kPa / bar) | 1000 kPa / 10 bar |
| Connections | Inlet | 1" BSP |
| | Outlet | 1" BSP |
| Manifold | Manifold construction | Stainless steel |
| | Pump isolation valves | Full bore, lever |
| Pump | Number of pumps | 1 |
| | Pump type | Multistage centrifugal (horizontal) |
| | Pump body | Stainless steel |
| | Impeller | Stainless steel |
| | Mechanical seal | EPDM / Silicon Carbide / Carbon |
| | Motor type | Induction (current overload sensor) |
| | Duty rating | Continuous (S1) |
| Electrical | Power supply / phase / frequency | 230 V / 1 / 50Hz |
| | Power consumption | 0.75 kW |
| | Current - full load | 3.4 Amps |
| Physical | Enclosure protection | IP55 |
| | Width | 268 mm |
| | Depth | 488 mm |
| | Height | 815 mm |
| | Weight | 24 kg |

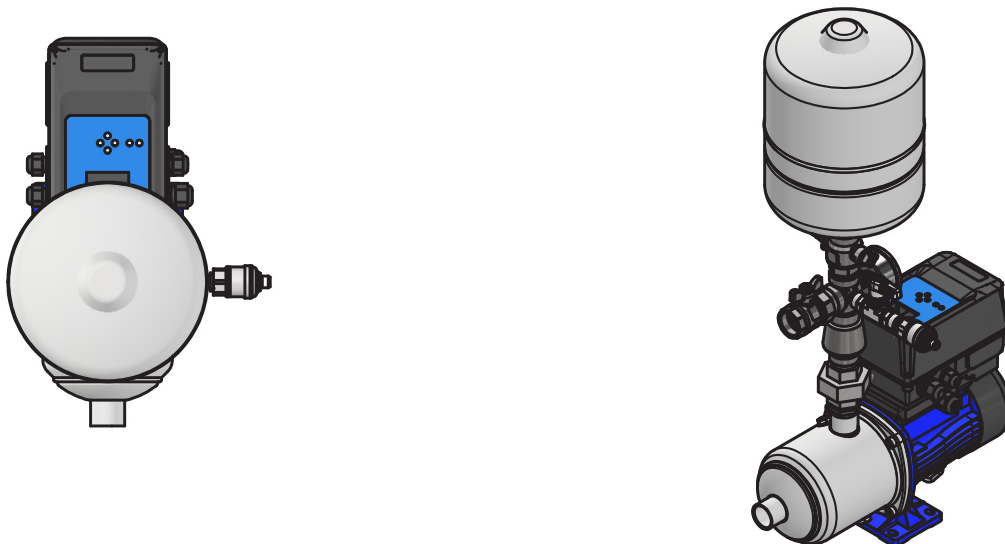
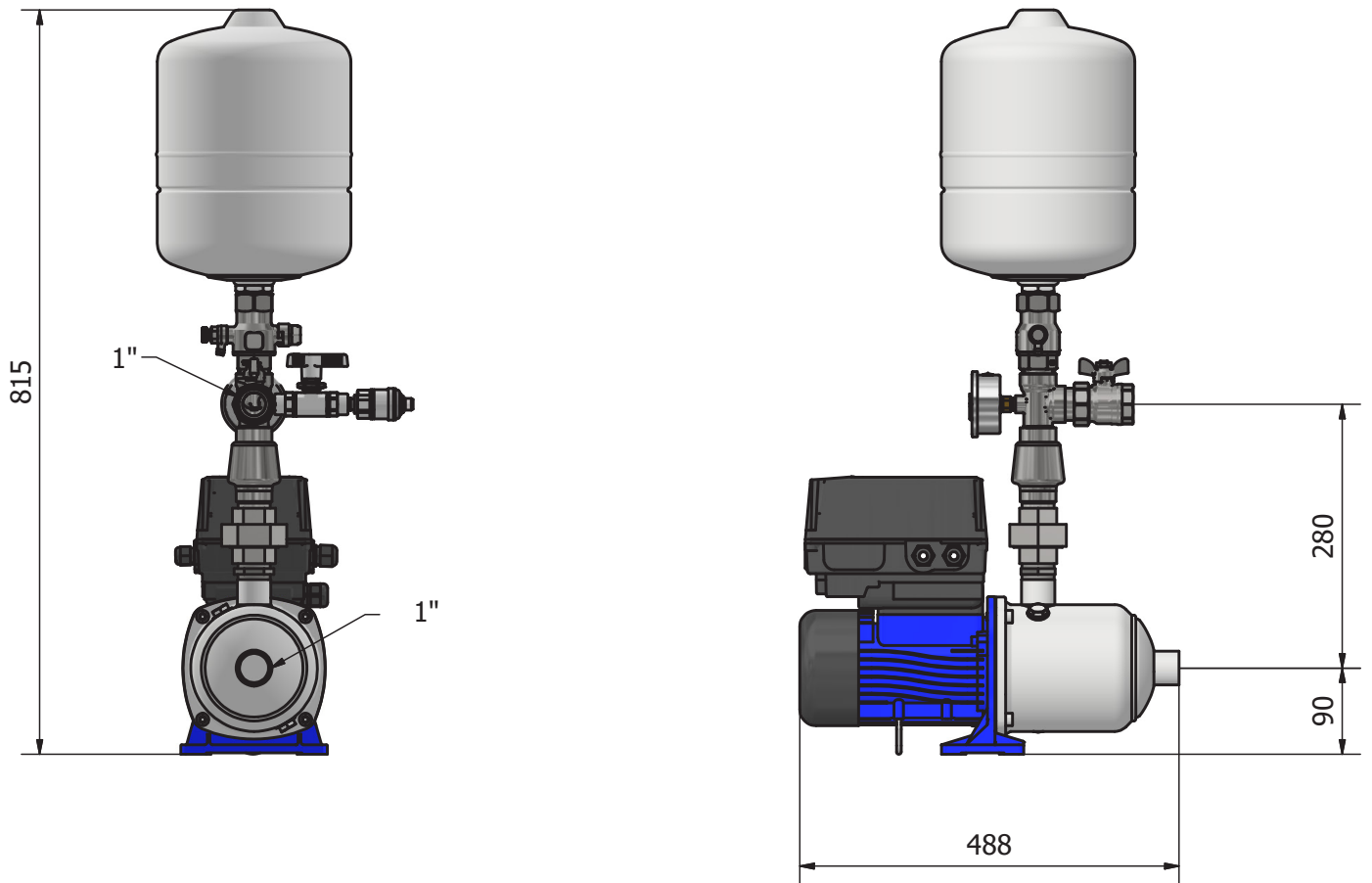

Stuart Turner Limited reserves the right to amend specifications without notice.

Stuart Turner Ltd, Henley-on-Thames, Oxfordshire RG9 2AD Tel: +44 (0) 1491 572655 Fax: +44 (0) 1491 573704
TechAssist Helpline +44 (0) 800 31 969 80
www.stuart-turner.co.uk

Model No. SPIV-3HM08S-VARiFLO-8 Issue 4222-01-02