

Notes:

1. This drawing is for 'Dimensional Information' only. It is essential that this drawing is read in conjunction with the 'Installation Guidelines' supplied with the unit (copies available from the sales department)
2. Inlet/Overflow pipe connections are 110 mm PVCu.
3. Pump Outlet and Mains Top up connections are Ø25 mm (3/4")
4. Electrical and water connections from the tank to appliances to be the responsibility of others.
5. Tank has a trimmable Inlet Invert from 220mm to 720mm. Neck can be trimmed at 100mm increments to required Invert. Refer to drawing DS1296P.
6. Keys supplied to open the Pedestrian duty covers latches.
7. Dry Site and Wet Site: Backfill with Concrete
8. Tank Weight (Empty) - 250 Kgs

Strapping Positions				
Unit	1	2	3	4
GRW110	315mm	460mm	460mm	315mm

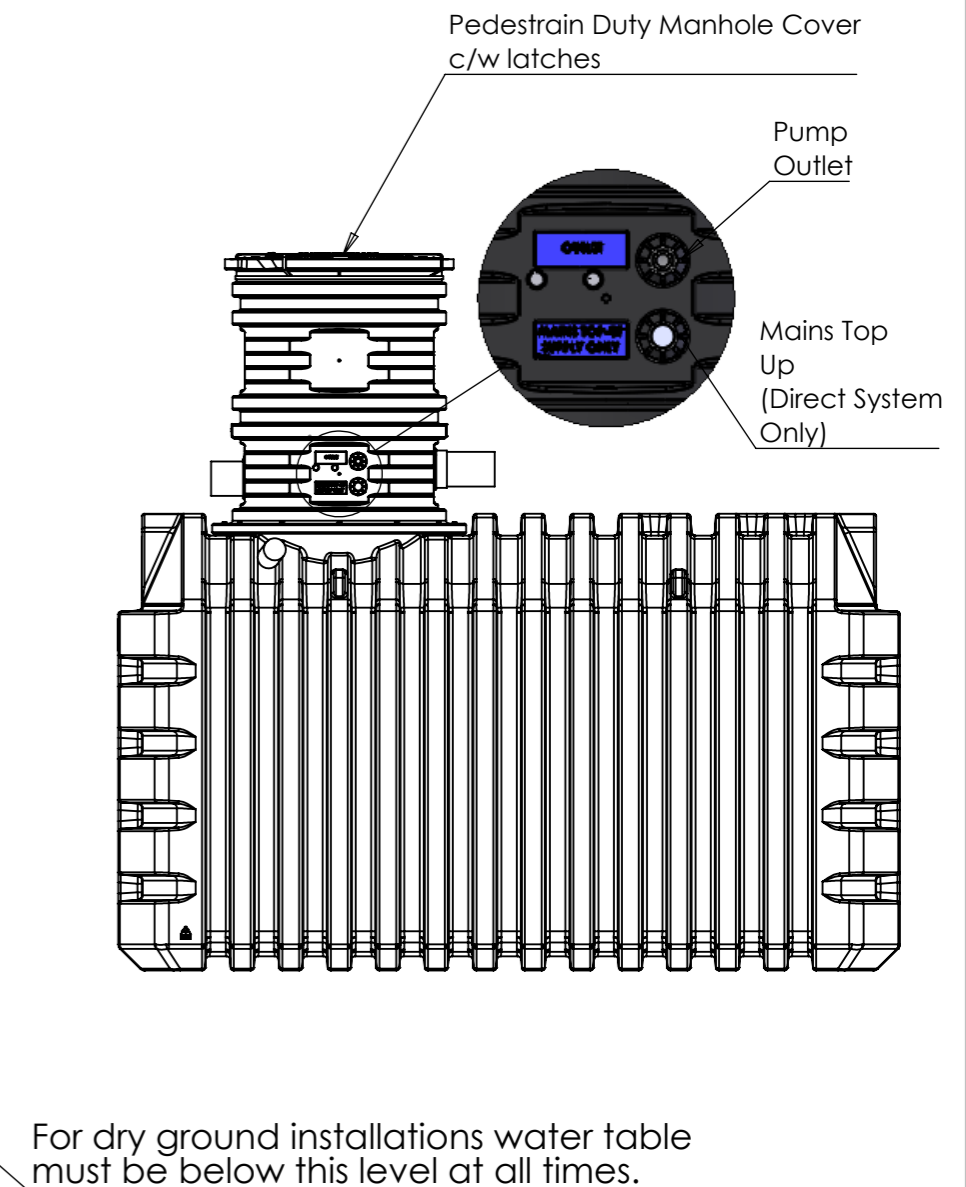
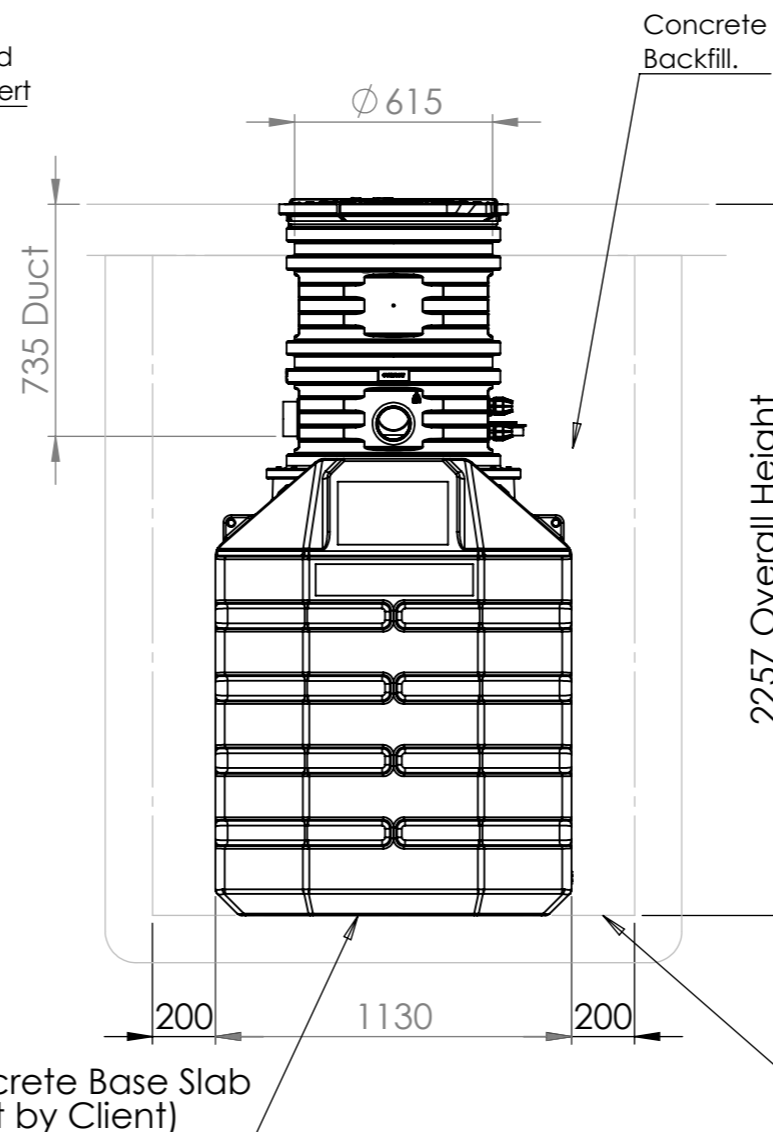
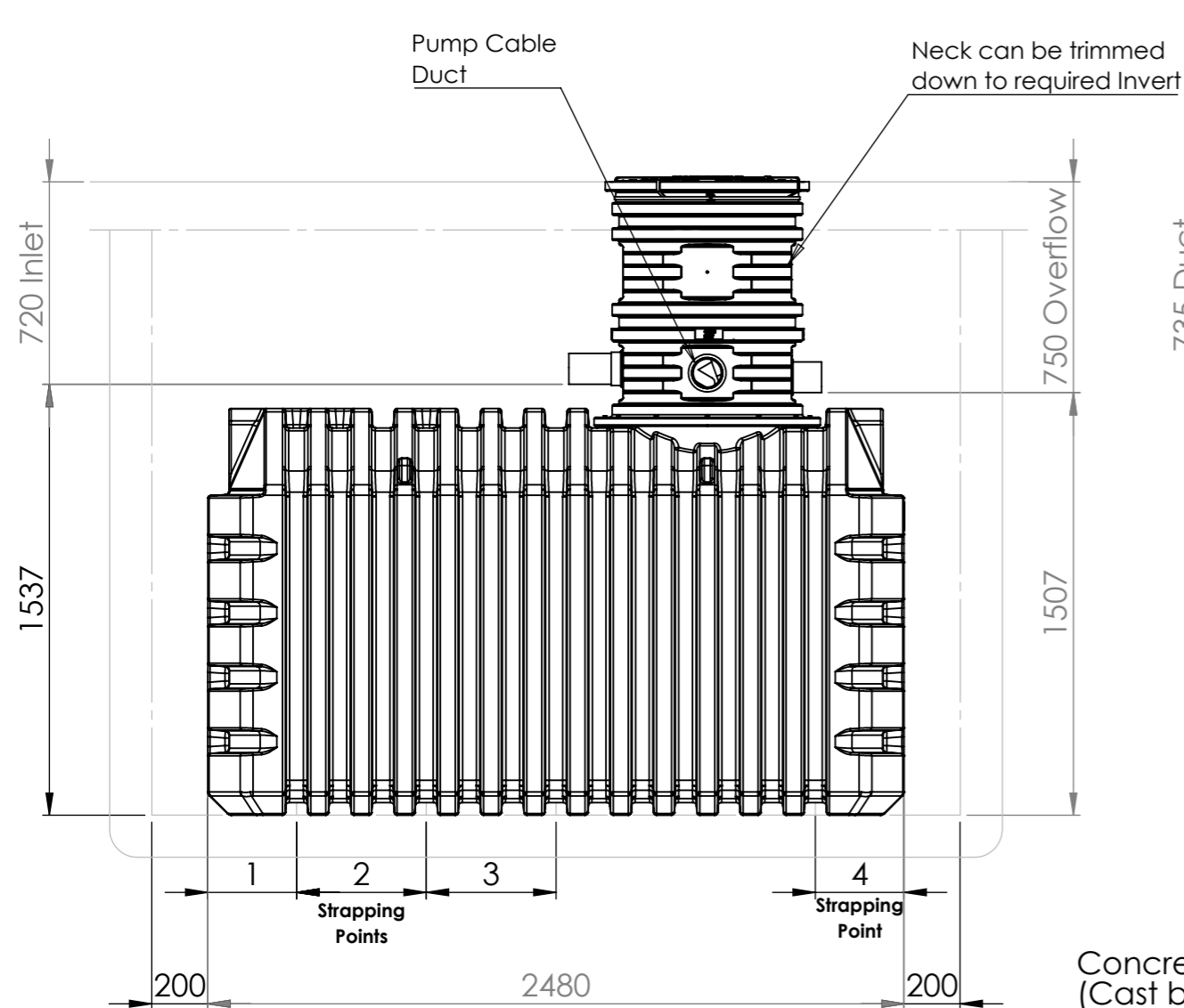

Please check with Kingspan Environmental that this drawing is the latest issue				
Issue	Date	Drawn by	Approved by	Description
03	29/05/22	JMcM	JMcM	ECN1609 - AquaHarvest Domestic
02	21/01/21	DM		CC1545 - Peashingle removed

LN Number :	Tolerance (unless stated) :
Finish :	Thickness : n/a
Weight : See Notes	Surface Area : m ²
Modelled By : Name	Material : Various

Drawing : DS1294P	Page 1 of 1
GRW110 - AquaHarvest Domestic - 3100L	

All Dimensions In mm Scale: Do Not Scale Third Angle Projection

M:\Wastewater\Engineering\Drawing Data\02 - Sales Drawings\DS\DS - 12\DS1294P

Kingspan Water & Energy reserve the right to alter the details of this drawing without prior notice. This drawing is copyright and may not be reproduced or used without the written permission of Kingspan Water & Energy

