

1. Place **A** on a flat surface

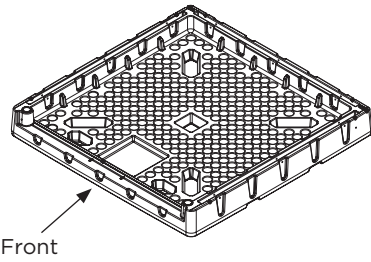

2. Insert **B** into the back of **A**

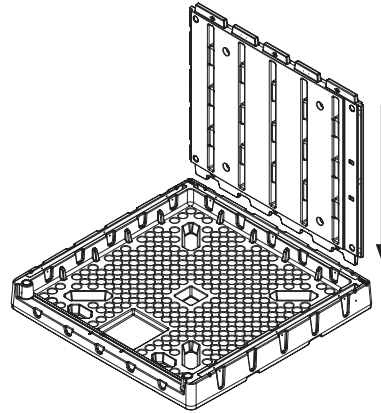

3. Insert **C** into **A** (one at a time) making sure corner joints intersect

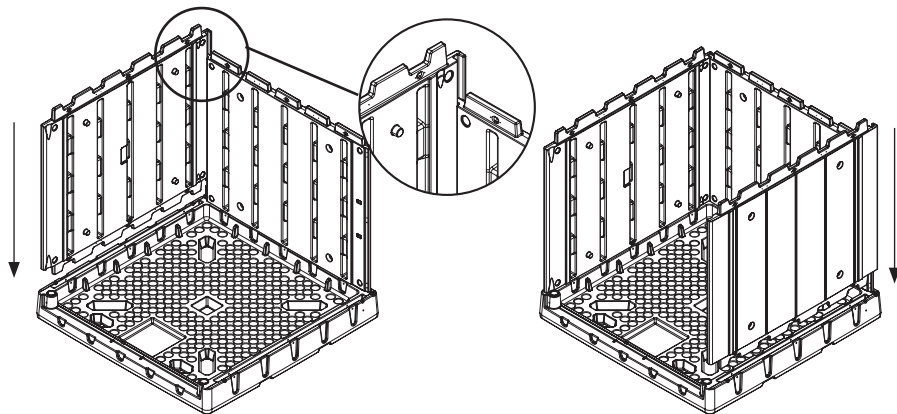

4. Forklift **D** onto **B** & **C** making sure **B** & **C** locate into **D**

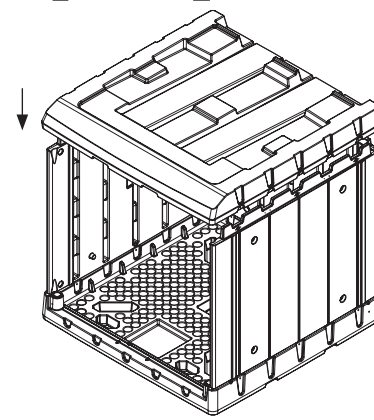

5. Insert **E** into **A** & **D**

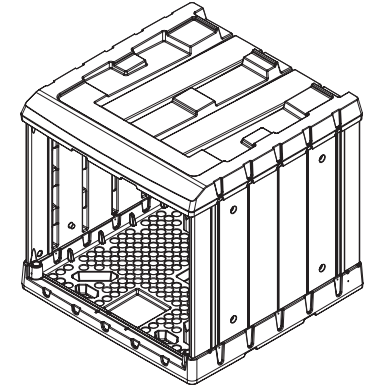

First, insert bottom pin into **A**

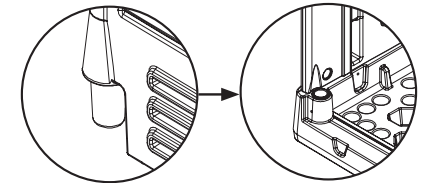

Lift **D** slightly for **E** to slot in at the top.

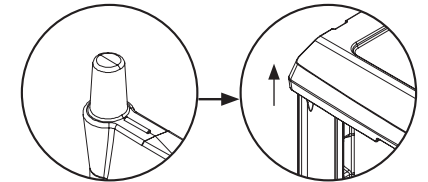

6. Repeat step 5 for **F** into **A** & **D**

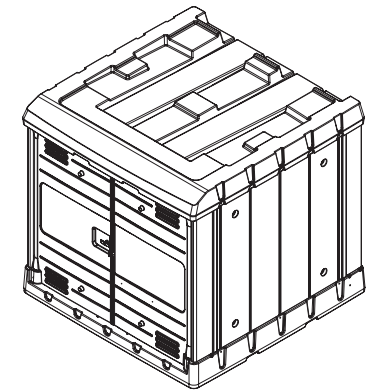
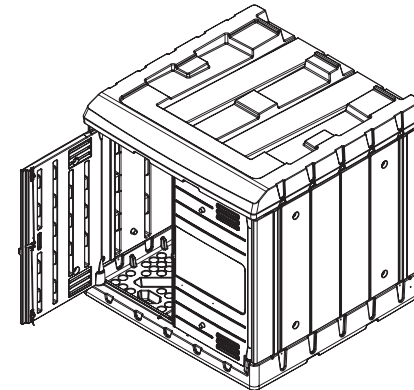

7. Secure **A** & **D** into place with **G** on all 18 fixing points  
Secure **B** & **C** into place with **E** on all 4 fixing points

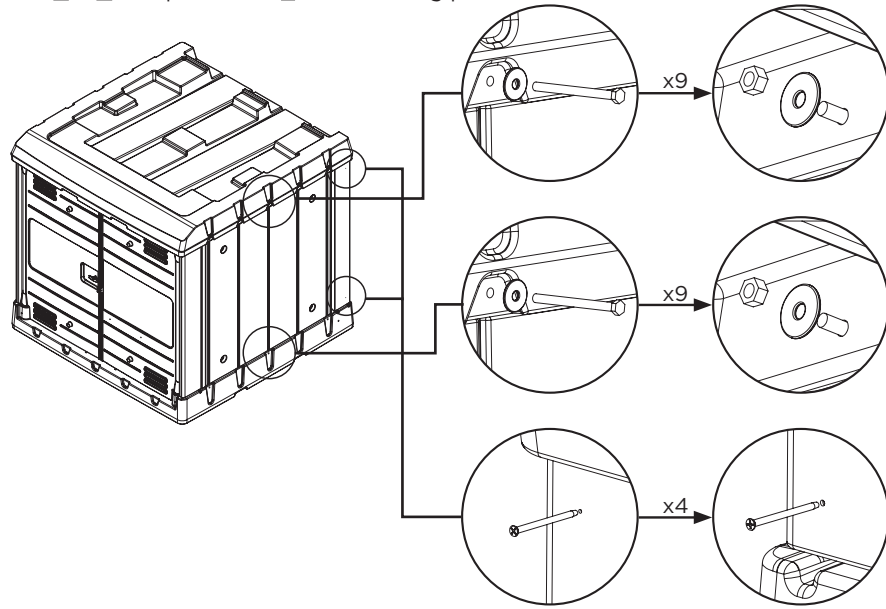

8. **IMPORTANT!** Make sure spill pallet central supports are in place before completing assembly

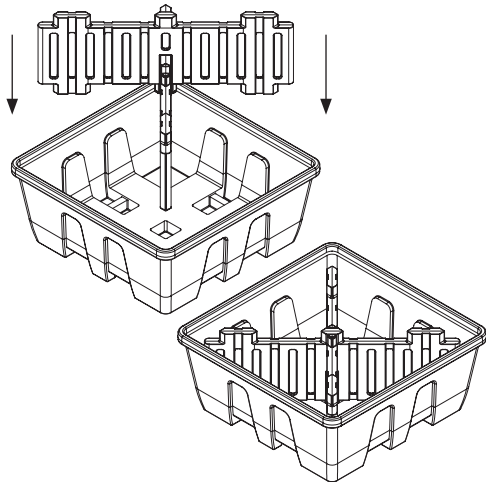

9. Forklift IBC Hardcover onto spill pallet central supports using forklift pockets, making sure platform aligns with central supports

